



LL 316



LL 316

NACECARE



Original Instructions
Warning! read instructions before using the machine



Operator Instruction Manual

Mode d'emploi



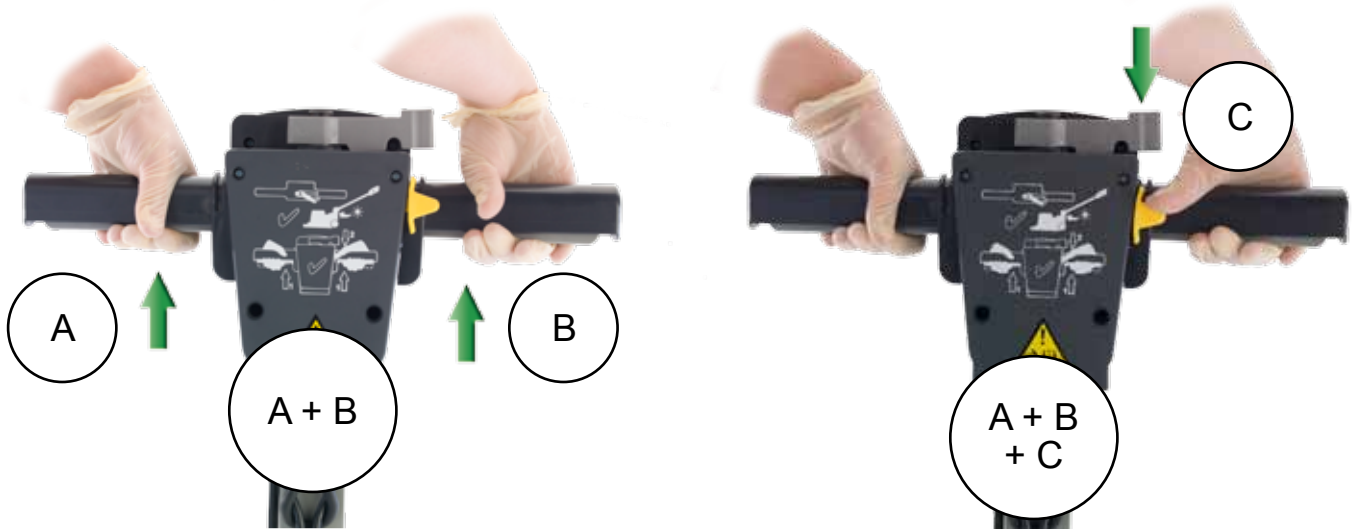

Auto - Stop

30 mins



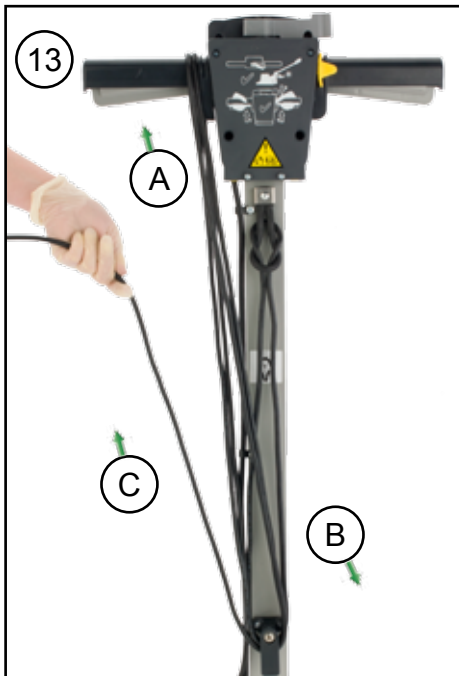

Optional extra (FMA - 606101) NLL Solution Tank





Rating Label

Company Name
and Address



Safety Critical Components

Mains Lead

15M x 3 x 16 awg

Floor Machine, accessories and packaging should be sorted for environmentally - friendly recycling



Only for EU countries:

Do not dispose of Floor Machine into household waste!
According to the European Directive 2002/96/EC on Waste Electrical and Electronic Equipment and its incorporation into national law. Floor Machine that are no longer suitable for use must be separately collected and sent for recovery in an environmentally - friendly manner.

PPE
(personal protective equipment)
that may be required for certain operations.



Safety Footwear



Hat Protection



Hi Viz Jacket



Ear Protection



Safety Gloves



Dust / Allergens Protection



Eye Protection



Protective Clothing



Caution Floorsign

NOTE:

A risk assessment should be conducted to decide what PPE should be worn.

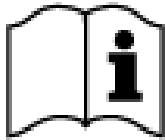

ORIGINAL INSTRUCTIONS
READ MANUAL BEFORE USE

Information for Floor Machines

CAUTION:

Read the instruction manual before using the appliance

NOTE:

This Product meets the requirements of BS EN 60335 - 2-67

This Machine is also suitable for commercial use, for example in hotels, schools, hospitals, factories, shops, rental businesses and offices for other the normal housekeeping purposes.

Care should be taken in the choice of chemicals, detergents and other liquids. Consult your supplier.

This appliance is not intended for use by persons (including children) with reduced physical sensory or mental capabilities, or lack of experience and knowledge.

Do's and Don'ts:

- DO Ensure only competent persons unpack/ assemble the machine.
- DO Keep your machine clean.
- DO Keep your brushes in good condition.
- DO Replace any worn or damaged parts immediately.
- DO Daily examine the mains lead for damage, such as cracking or aging. If damaged is found, replace the lead before further use.
- DO Only replace the mains lead with the correct Numatic approved replacement part.
- DO Ensure that the work area is clear of obstructions and/ or people.
- DO Ensure that the working area is well illuminated.
- DO Pre - sweep the area to be cleaned.

- DON'T Use steam cleaners or pressure washers to clean the machine or use in the rain.
- DON'T attempt machine maintenance or cleaning unless the power plug has been removed from the supply outlet.
- DON'T Allow any inexperienced repairs. Contact your nearest service centre.
- DON'T Strain the mains lead or try to unplug by pulling on the mains lead.
- DON'T Leave the brush deck in the lowered position when not in use.
- DON'T Expect the machine to provide trouble free, reliable operation unless maintained correctly.
- DON'T Run the machine over any power cables during operation.

WARNING:

Operators shall be adequately instructed on the use of this machine.

This machine shall be disconnected from its power source (Remove plug from socket outlet.) During cleaning or maintenance or in the event of an accident and when replacing parts or converting the machine to another function.

This machine is not suitable for picking up hazardous dust.

Do not allow supply cord to come into contact with the rotating brushes or pads

As with all electrical equipment care and attention must be exercised at all times during its use, in addition to ensuring that routine and preventive maintenance is carried out

Periodically in order to ensure its safe operation. Failure to carry out maintenance as necessary, including the replacement of parts to the correct standard could render the equipment unsafe and the manufacturer can accept no responsibility or liability in this respect.

When ordering spare parts always quote the model number / serial number specified on the rating plate.

This machine is for indoor use only.

The machine is not to be used or stored outdoors or in wet conditions.

Don't allow the machine to be used by inexperienced or unauthorised operators or without appropriate training.

Only use brushes provided with the appliance or those specified in the instruction manual.

The use of other brushes may impair safety.

A full range of brushes and accessories are available for this product.

Only use brushes or pads which are suitable for the correct operation of the machine for the specific task being performed.

It is essential that this equipment is correct assembled and operated in accordance with current safety regulations. When using the equipment always ensure that all necessary precautions are taken to guarantee the safety of the operator and any other persons who may be affected.



Sur la machine

Nom et adresse de la société

Plaque signalétique

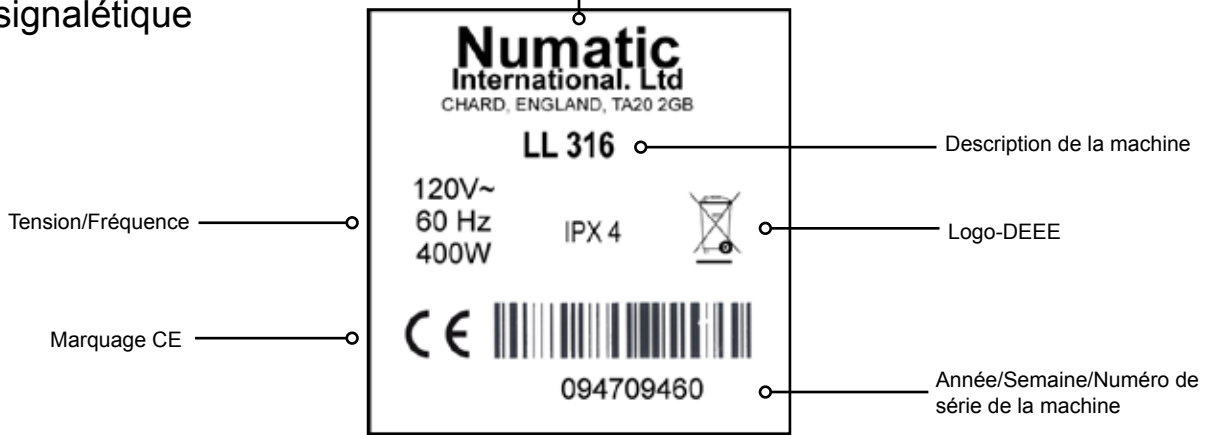

Composants critiques pour la sécurité

Câble d'alimentation

15M x 3 x 16 awg

Législation WEEE (DEEE)

Monobrosse, ses accessoires et son emballage doivent être triés pour un recyclage écologique.

Pays de l'UE uniquement :

Ne jetez pas Monobrosse avec les ordures ménagères.

Selon la directive européenne 2002/96/CE relative aux déchets d'équipements électriques et électroniques (DEEE) et à sa transposition au droit national, Monobrosse qui ne sont plus utilisables doivent faire l'objet d'une collecte sélective et être traités d'une manière respectueuse de l'environnement.



EPI

(Equipelement de protection individuelle)

Il peut être nécessaire pour certaines opérations.



Chaussures de sécurité



Casque de protection



Gilet de haute visibilité



Protections sonores



Gants de sécurité



Protection contre la poussière/les allergènes



Protection des yeux



Vêtements de protection



Panneau de signalisation au sol

Note :

Une évaluation des risques devra être menée pour définir les obligations d'utilisation des EPI.

(sujet à modification sans préavis)



Veillez lire le manuel d'instruction avant d'utiliser l'appareil.
Les utilisateurs doivent être correctement formés à l'utilisation de ces appareils.

Informations concernant Monobrosse

MISE EN GARDE :

Lisez le mode d'emploi avant d'utiliser l'appareil.

REMARQUE :

Ce produit est conforme aux exigences de la norme BS EN 60335 - 2-67

Cette machine est également adaptée à un usage commercial, par exemple pour les hôtels, les écoles, les hôpitaux, les usines, les magasins, sociétés de location et les bureaux à des fins autres que les besoins ménagers normaux.

Un soin particulier doit être pris dans le choix des produits chimiques, détergents et autres liquides. Consultez votre fournisseur.

Cet appareil n'est pas destiné à être utilisé par des personnes (y compris des enfants) avec des capacités physiques, sensorielles ou mentales réduites, ou manquant d'expérience et de connaissances, sauf si elles ont reçu des consignes ou des instructions quant à l'utilisation de l'appareil par une personne responsable de leur sécurité.

Choses à faire et à ne pas faire :

Veillez à ce que seules des personnes compétentes déballent/assemblent la machine.

Maintenez votre machine propre.

Maintenez vos brosses en bon état.

Remplacez immédiatement toute pièce usée ou endommagée.

Examinez régulièrement le câble d'alimentation pour voir s'il comporte des traces d'endommagement telles que des fissures ou un vieillissement. S'il est endommagé, remplacez-le avant toute nouvelle utilisation.

Remplacez le câble d'alimentation uniquement avec la pièce de rechange correcte approuvée par Numatic.

Assurez-vous que la zone de travail n'est pas encombrée et que personne ne passe par là.

Assurez-vous que la zone de travail est bien éclairée.

Balayez au préalable la zone à nettoyer.

N'utilisez pas de nettoyeurs à vapeur ou de nettoyeurs haute pression pour nettoyer la machine et évitez toute utilisation sous la pluie.

Ne procédez pas à l'entretien ou au nettoyage de la machine tant que celle-ci est branchée dans la prise de courant.

Ne laissez pas des personnes inexpérimentées effectuer des réparations. Contactez votre centre de service le plus proche.

N'exercez pas de traction excessive sur le câble, et ne débranchez jamais le câble en tirant dessus.

Ne laissez pas le plateau de brosses dans la position abaissée lorsqu'il n'est pas utilisé.

Ne négligez pas l'entretien de la machine si vous souhaitez qu'elle fonctionne de manière fiable et sans problème.

Ne roulez pas avec la machine sur des câbles électriques pendant l'utilisation.

ATTENTION :

Les opérateurs doivent recevoir des instructions appropriées sur l'utilisation de ces machines.

Cette machine doit être débranchée de sa source d'alimentation (retirez la fiche secteur de la prise de courant) pendant le nettoyage ou l'entretien, ou en cas d'accident, ou pendant le remplacement de pièces ou la conversion de la machine pour changer de fonction.

Cette machine n'est pas conçue pour le ramassage de poussières dangereuses.

Ne laissez pas de fil électrique entrer en contact avec les brosses ou disques

Comme pour tout équipement électrique, il convient d'être prudent et vigilant à tout instant lorsqu'on l'utilise, en plus de s'assurer que son entretien courant et préventif est bien effectué régulièrement pour qu'il reste en bon état de fonctionnement. Si l'entretien nécessaire n'est pas effectué et si l'on ne remplace pas les pièces à changer par des pièces à la bonne norme, l'équipement pourrait devenir dangereux et le fabricant ne pourra accepter aucune responsabilité à cet égard.

Lorsque vous commandez des pièces de rechange, indiquez toujours le numéro du modèle / numéro de série indiqué sur la plaque signalétique.

Cette machine est réservée à un usage intérieur.

La machine ne doit pas être utilisée ni rangée à l'extérieur ou dans un environnement humide.

Ne laissez pas des opérateurs inexpérimentés, non autorisés ou sans formation appropriée utiliser la machine.

Utilisez uniquement les brosses fournies avec l'appareil ou celles qui sont spécifiées dans le mode d'emploi.

L'utilisation d'autres brosses peut nuire à la sécurité.

Une gamme complète de brosses et d'accessoires est disponible pour ce produit.

N'utilisez que des brosses ou des disques qui sont appropriés pour le fonctionnement correct de la machine pour la tâche spécifique effectuée.

Il est essentiel que cet équipement soit correctement monté et utilisé conformément aux normes de sécurité actuelles. Lors de l'utilisation de l'équipement, veillez toujours à ce que toutes les précautions nécessaires soient prises pour garantir la sécurité de l'opérateur et de toute autre personne qui pourrait être concernée.

Hazardous regulation information / Data.



Under certain uses, this machine may be subject to the Provision and Use of Work Equipment Regulations (council directive 89/655/EEC), Control of Substances Hazardous to Health

Regulations, Dangerous Substances and Explosive Atmospheres Regulations and other Safety Regulations (council directive 98/24/EC & 99/92/EC). User must ensure that their use of this machine for any purpose meets these requirements.

Regular inspection and maintenance of this machine in accordance with the manufacturer's recommendations and the above Regulations is essential for its functional and safe operation.

Model	Motor	Speed	Brush	Pad	Range	Weight	Sound Pressure dB(A)@1.7M	HAV M/S ²	Dimensions
LL 316	500W	160rpm	330mm	330mm	32m	18 kg	66.6	2.1	1145x330x540mm
HAV = Hand Arm Vibration (uncertainty +/- 0.05m/s ²)									



Pour certaines utilisations, cette machine pourra être soumise aux réglementations suivantes :

Directive 89/655/CEE du Conseil concernant les prescriptions minimales de sécurité et de santé pour l'utilisation par les travailleurs au travail d'équipements de travail "Provision and Use of Work Equipment Regulations".

-Directives 98/24/CE et 99/92/CE du Conseil du Conseil concernant la protection de la santé et de la sécurité des travailleurs contre les risques liés à des agents chimiques sur le lieu de travail et autres réglementations concernant la sécurité

"Control of Substances Hazardous to Health Regulations, Dangerous Substances and Explosive Atmospheres Regulations and other Safety Regulations".

Les utilisateurs doivent s'assurer que leur usage de cette machine pour une application quelconque soit bien conforme à ces exigences.

Afin que cette machine fonctionne correctement et en toute sécurité, il est essentiel qu'elle soit périodiquement contrôlée et entretenue conformément aux recommandations du constructeur et aux Réglementations ci-dessus.







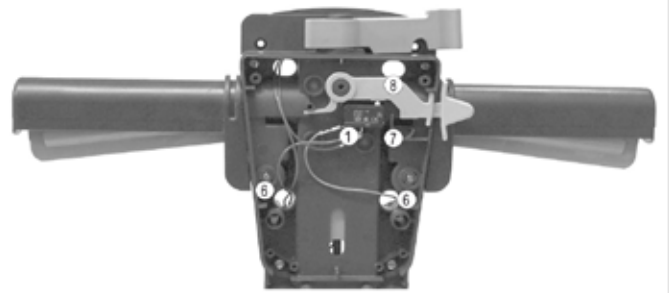
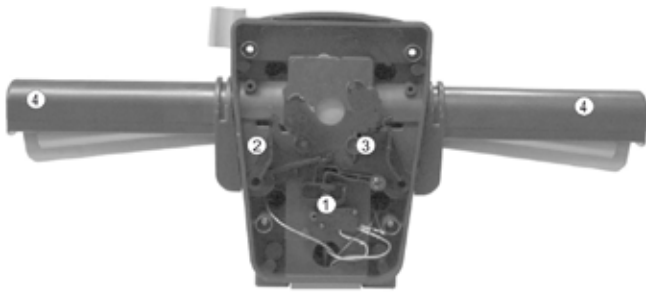

Model	Moteur	Vitesse	Brosse	Disque	Rayon de travail	Poids (prête à l'emploi)	Joint de séparateur dB(A)@1.7M	HAV M/S ²	Dimensions
LL 316	500W	160rpm	330mm	330mm	32m	18 kg	66.6	2.1	1145x330x540mm
HAV = Mesure des vibrations main-bras (uncertainty +/- 0.05m/s ²)									

Dimensions



















NLL 316 Floorcare Accessories



	Part No.	Description.		Part No.	Description.
	1. 229453	SNAP ACTION SWITCH		5. 227581	TRIGGER MOULDING
	2. 227586	RH OPERATING LEVER		6. 219803	TRIGGER SPRING
	3. 227585 219804 219805 227587	LH OPERATING LEVER SWITCH SPRING 4MM SPIREFIX CENTRE SWITCH MOULDING		7. 227584	SWITCH LEVER
	4. 227580	HANDLE MOULDING		8. 227583	ADJUSTMENT LEVER







	1. 229081	HANDLE CASTING		6. 229484	HANDLE LOCKING ROD
	2. 229482	ADJUSTMENT GEAR (DUAL SETTING)		7. 229030	ANTI VIBRATION PAD
	3. 229073	GEAR LOCKING PIN		(NOT SHOWN) 227582	HANDLE END PLUG
	4. 229138	GEAR LOCKING SPRING			
	5. 429096	HANDLE PAINTED			

	206576	120V DC RELAY		8. 236083	15.0MT x16AWGx 3CORE CABLE (CSA).
	221048	20uf MOTOR RUN CAPACITOR		219345	EXTERNAL CIRCLIP
	229454	HANDLE SWITCH		219891	WAVE WASHER
				329112	GREY WHEEL
				206723	AXLE

Wet Scrubbing	Spray Cleaning	Light Spray Buffing	Low Gloss Polish	Meduim Gloss Polish
1	2	3	4	5
0	0	0	0	0
NACECARE				

LoLine LL 316 Accessories - 330mm

	330mm Union Mix Polish Brush 4 - 5		330mm Polyscrub Brush 1
	330mm Nyloscrub Brush 1		330mm Nuloc Pad Drive Board 1 - 2 - 3 - 4 - 5



NLL - 316 (NACE, Floor Machine)

WD - 0349 (A05) 07.04.10

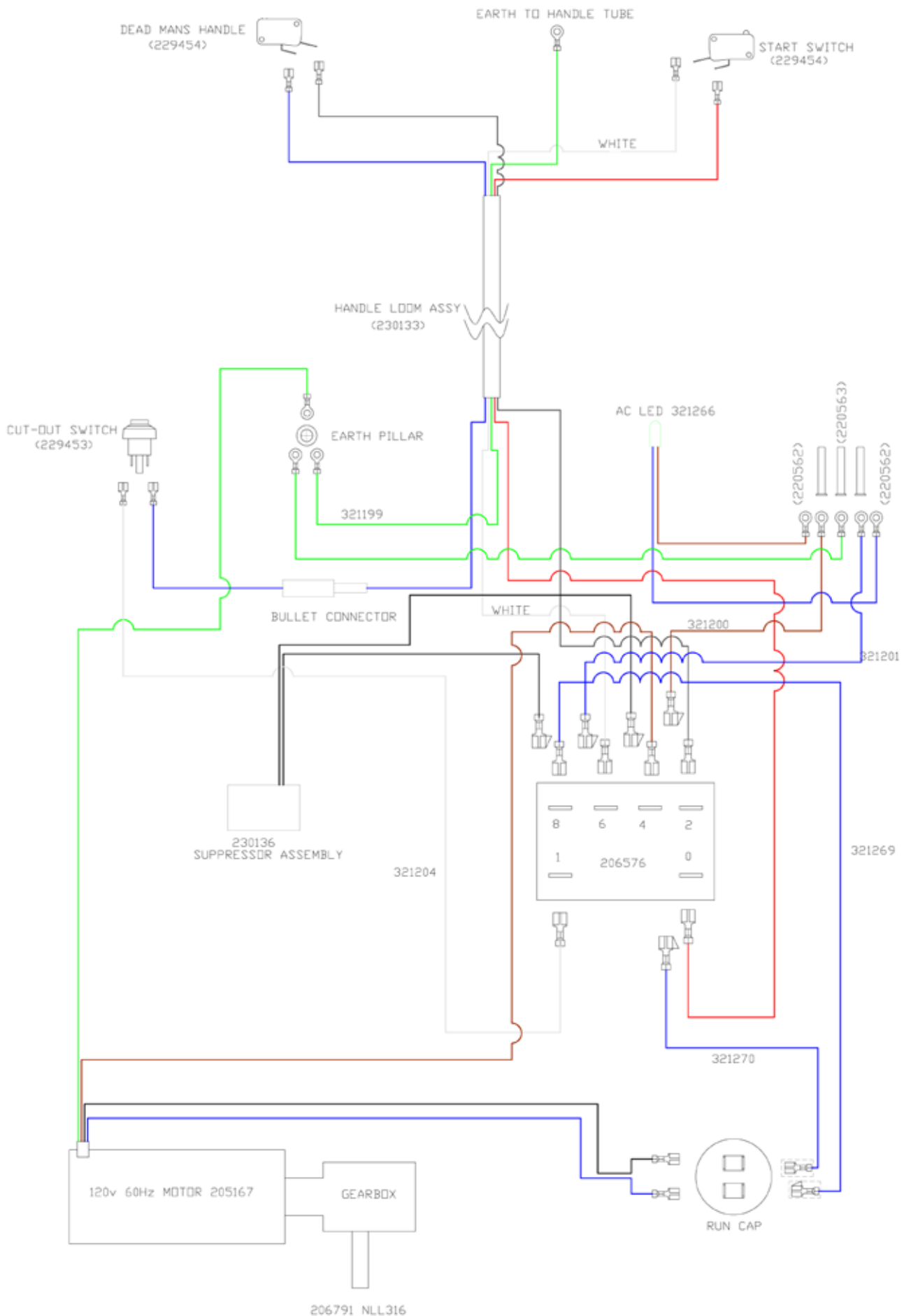



Distributed by:

This Product has been comprehensively inspected and checked during every stage of its manufacture, including an in-depth electrical safety and functionality test.

NACECARE

1205 Britannia Road East
Mississauga Ontario L4W 1C7
Canada

Telephone: 9 00 1 905 795 0122

Fax: 9 00 1 905 795 0038

<http://www.nacecare.com>



Numatic International Limited, Chard, Somerset, TA20 2GB, ENGLAND.

Telephone 01460 68600 Fax: 01460 68458

www.numatic.co.uk

Specification subject to change without prior notice
www.numatic.co.uk © Numatic International Limited