

TGB 6055/100

TGB 6055/100T

BATTERY SCRUBBER DRYER

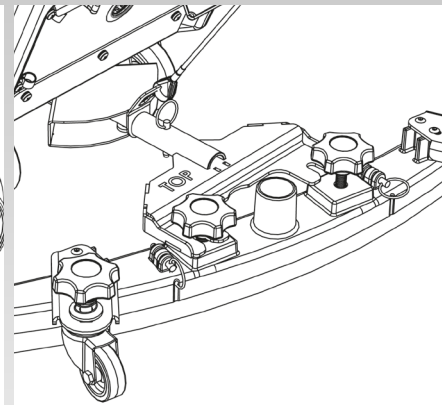
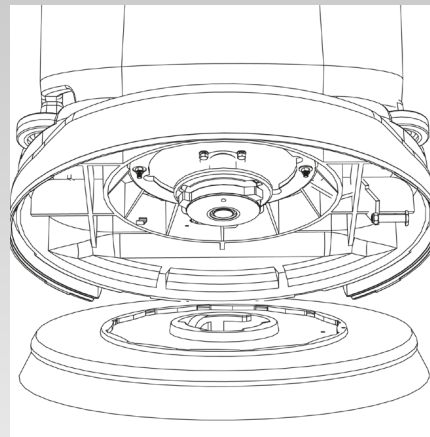

Owner Instructions

Warning! Read instructions before using the machine



BATTERY SCRUBBER DRYER

TGB 6055/100

Index

Machine Overview	Pages 2/3
Control Panel Overview	Page 4
Machine Set up Guide	Page 5
Fitting the Brush / Pad	Page 6
Fitting the Floor Tool	Page 6
Fitting the Hose Guide	Page 7
Filling the Clean Water Tank	Page 7
Fill Level Indicator	Page 8
Lowering the Floor Tool	Page 9
Raise / Lower Brush Deck.....	Page 9
Setting the Cleaning Controls	Page 9
Brush Pressure	Page 10
Breakaway Floor Tool	Page 10
Machine in Use	Page 10
Machine Cleaning	Page 11
Waste Water Tank Full	Page 11
Changing Floor tool Blades.....	Page 12
Machine Charging	Page 13
Battery Care	Page 14
Charging Lights Sequence	Page 14
TGB6055/100T Operation	Page 15/16
Specifications	Page 17
Trouble Shooting	Page 17/18
Rating Label / Personal Protective Equipment /Recycling	Page 19
Safety Precautions	Page 20/21
Recommended Spare Parts	Page 22
Schematic Diagram	Page 22
Battery Wiring	Page 23
EU Declaration Document	Page 24
Warranty	Page 25
Company Address	Page 28

PLEASE READ BEFORE COMMENCING OPERATION

After the removal of all the packaging, carefully open and check the contents

- Owner Manual • 2 x Ignition Keys
- Battery Charging Lead • 2 x 40 Amp Fuse (Battery) • 1 x 30 Amp Fuse (Brush)
 - 1 x 20 Amp Fuse (Vac)
- 1 x 2.5 Amp Fuse • Maxi Fuse-puller

For Charger-less Model, all the above plus:

- 1 x Charger Connector • 2 x Charger Connector Terminals • 4 x Battery Terminal Connectors • 1 x Fuse Holder

1	Operator control panel
2	Charging Socket / Point
3	Clean Water Fill Point
4	Floor Tool Raise / Lower Lever
5	Clean Water Tank Emptying Hose & Fill Level
6	Vacuum Hose
7	Charging Lights
8	Brush Deck Lifting Pedal
9	Extra Brush Load Pedal
10	Semi Parabolic Floor Tool
11	Brush On/Off / Control Handle
12	Safety Fuse 2.5 Amp
13	Batteries
14	40 Amp Battery Fuse (50 Amp in Traction Machine)
15	Brush Motor Fuse 30 Amp
16	Vac Motor Fuse 20 Amp
17	Brush Deck
18	Clean Water Filter
19	Water Flow Tap
20	Waste Water Emptying Hose
21	Separator
22	Top Tank (Waste Water)
23	Bottom Tank (Clean Water)
24	Detent Pin
25	Key Ignition. On/Off

Machine Overview

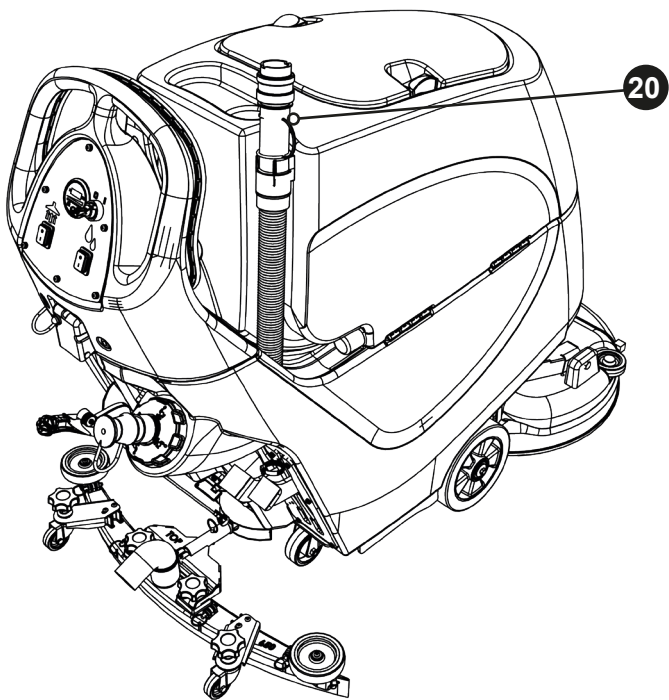
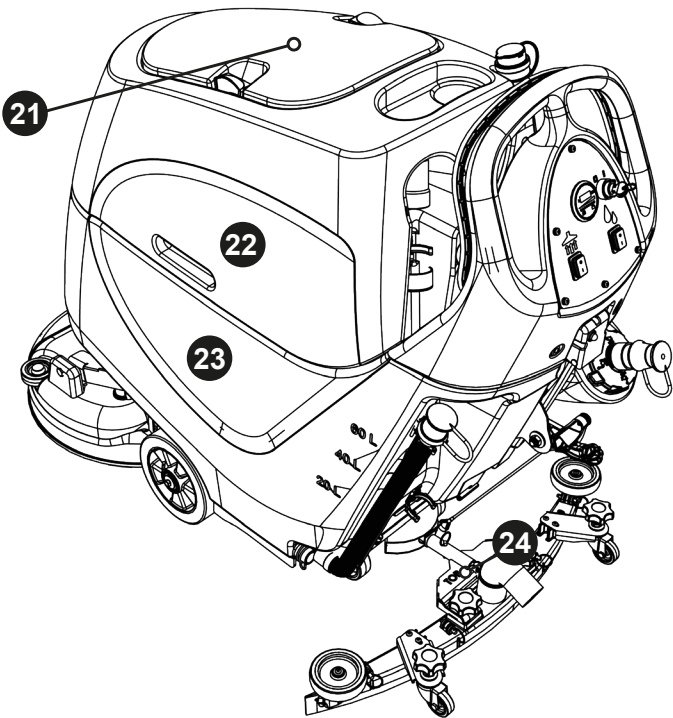
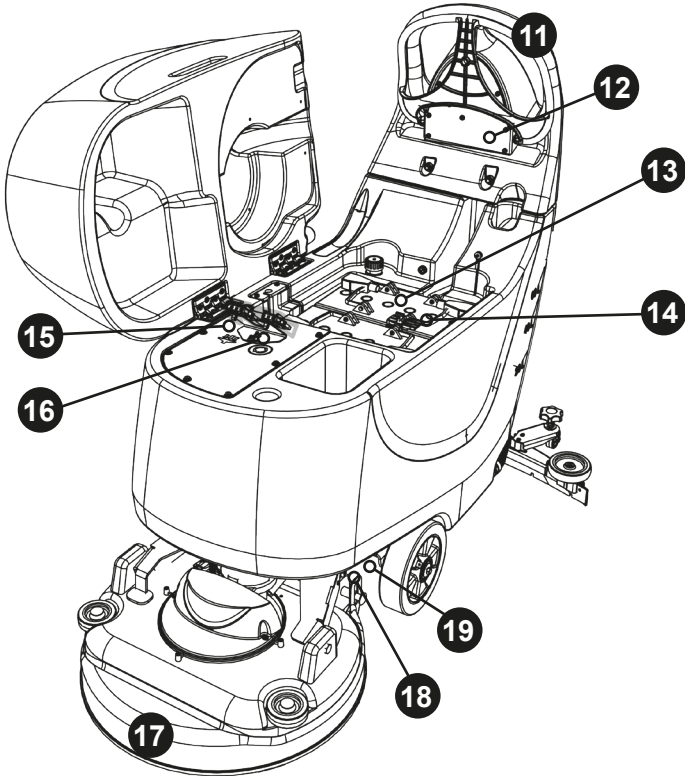
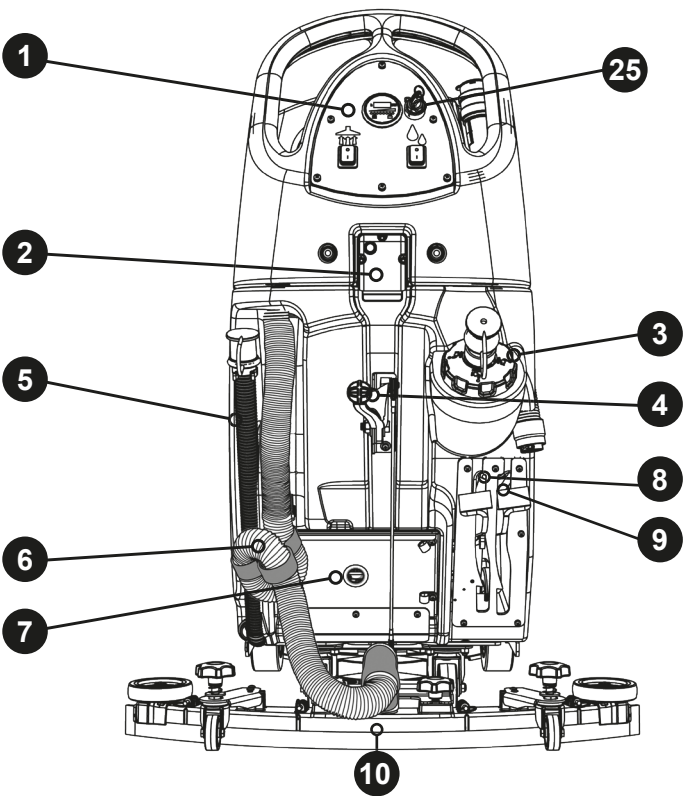

BATTERY SCRUBBER DRYER

TGB 6055/100

Control Panel Overview

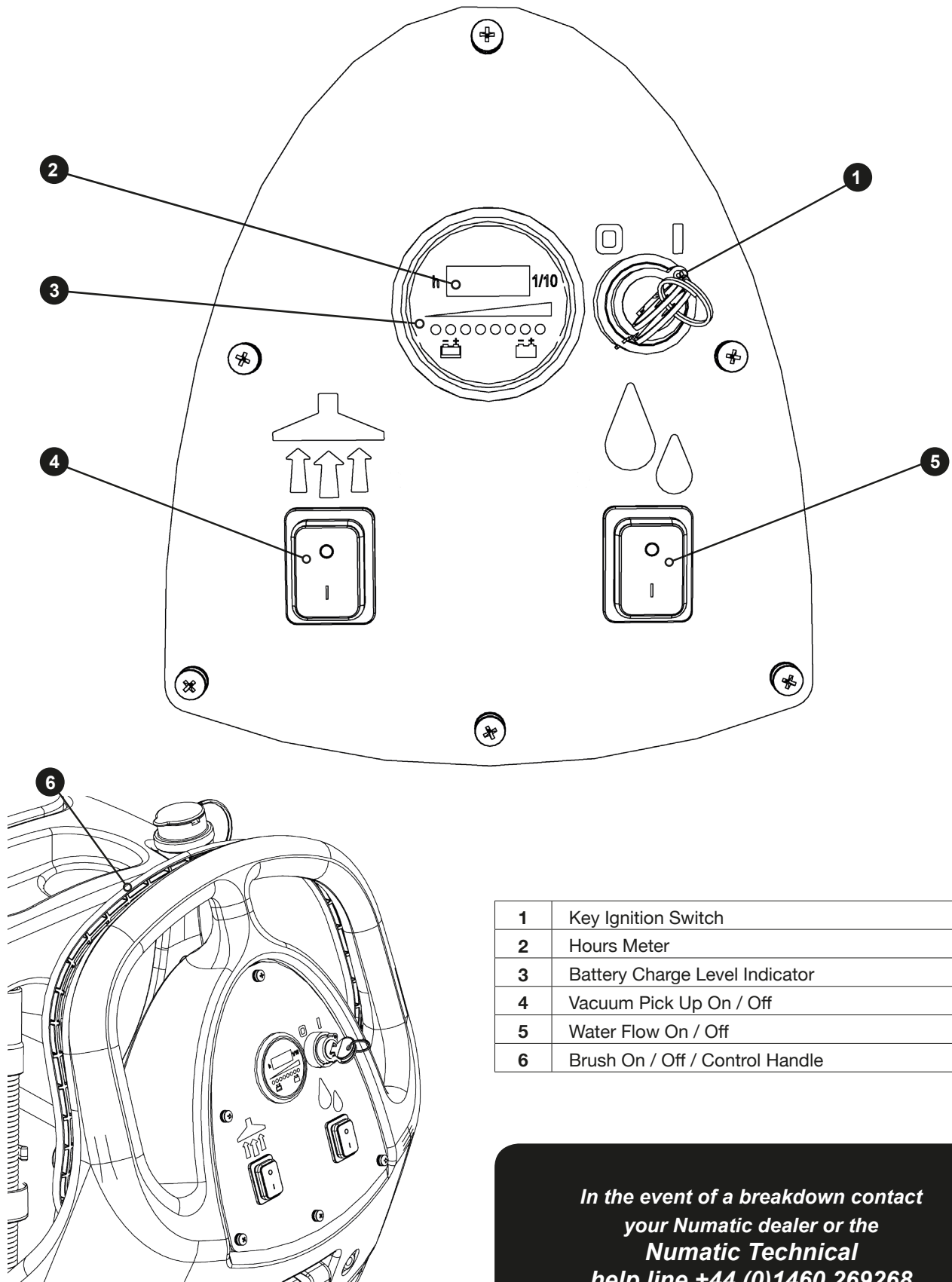

1	Key Ignition Switch
2	Hours Meter
3	Battery Charge Level Indicator
4	Vacuum Pick Up On / Off
5	Water Flow On / Off
6	Brush On / Off / Control Handle

*In the event of a breakdown contact
your Numatic dealer or the
Numatic Technical
help line +44 (0)1460 269268*

PLEASE READ BEFORE COMMENCING ANY OPERATION AFTER THE REMOVAL OF ALL THE PACKAGING, CAREFULLY OPEN AND CHECK THE CONTENTS.

TGB 6055/100 CONTENTS

- 2 x Ignition Keys • 2 x 40 Amp Fuse (Battery) • 1 x 30 Amp Fuse (Brush) • 1 x 20 Amp Fuse (Vac)
- 1 x 2.5 Amp Fuse • Maxi Fuse-puller
- For Charger-less Model, all the above plus:
- 1 x Charger Connector • 2 x Charger Connector Terminals
- 4 x Battery Terminal Connector covers • 1 x Fuse Holder

Lift top tank assembly to reveal battery compartment, ensuring you use the handle grip provided.

Fit battery fuse (contained in start-up pack) into the battery fuse holder as illustrated. (Fig. 1, 2, 3.)

Insert Key into ignition located on the control panel (See below (Fig. A))

NOTE: Wear suitable gloves when inserting fuses.

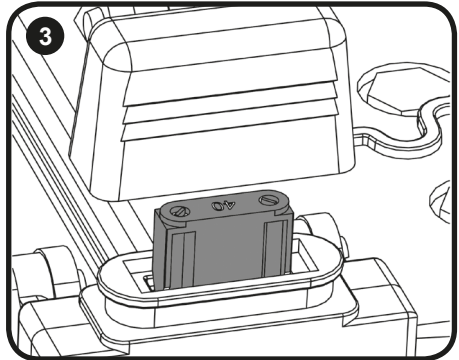
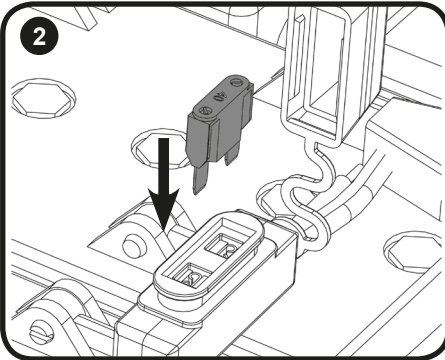
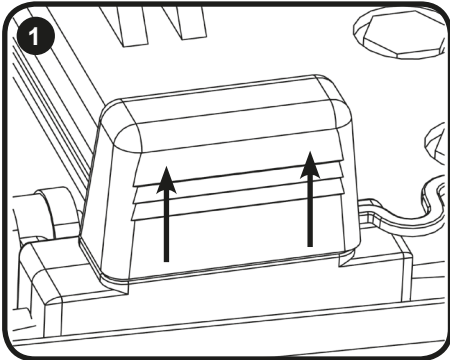
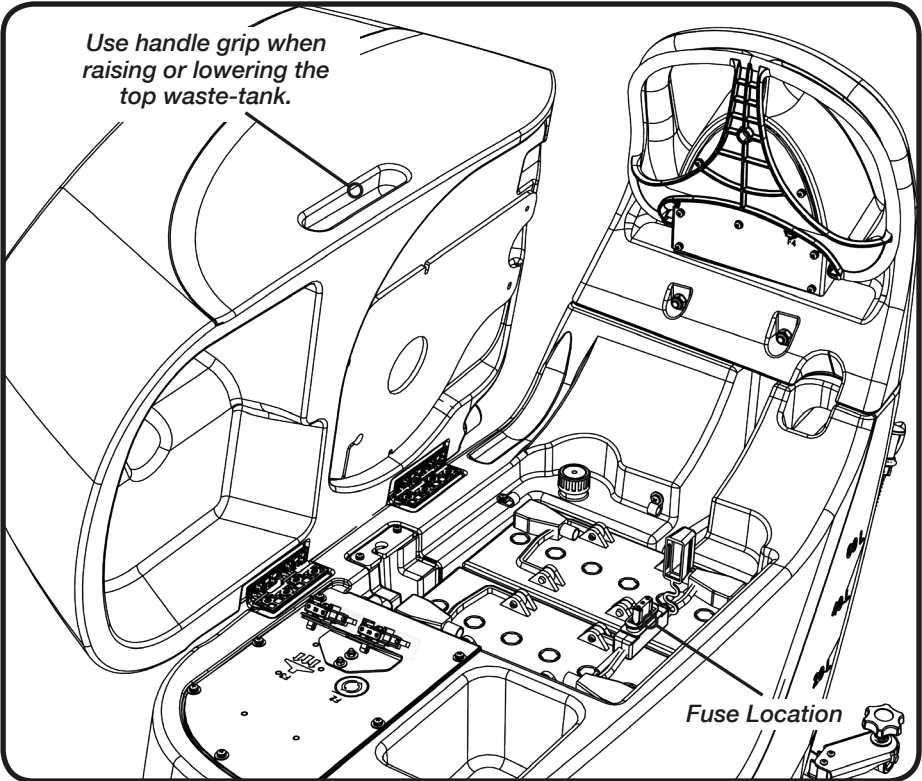

Less Battery Models - Numatic International Ltd recommends using MK Batteries for 6055 and 6055T in the TGB machines mentioned in this manual. For full battery specifications see page 22.

Ensure that no metal objects come into contact with battery terminals while the batteries are exposed. When inserting the first fuse you may notice a spark, this is normal.

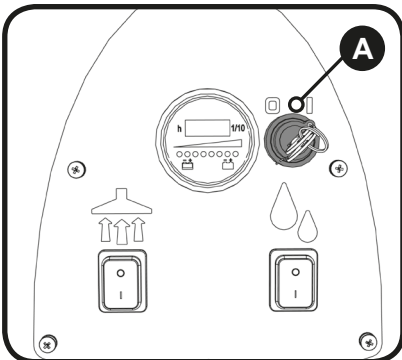

Insert the Ignition key and switch the machine on. (Fig. A)

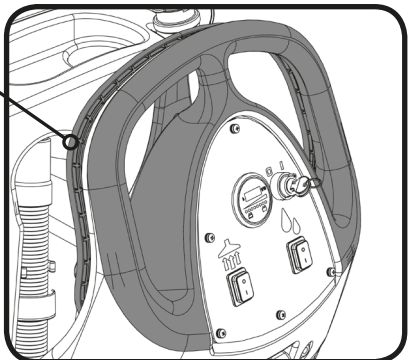

Using the control handle with both hands, slowly push the machine off the pallet. When the machine is removed and in a safe position, release the control handle.
Note: Do not pull the RED trigger handle while in transport mode (Fig. B)
 During vehicular transportation ensure the product is secured to avoid unnecessary movement.

Machine Set-up Guide



**ALWAYS ENSURE THAT THE MACHINE IS SWITCHED OFF
BEFORE MAKING ANY ADJUSTMENTS**



Fitting the Brush / Pad / Turn on water

550mm Brush or a 500mm Pad on the TGB 6055/100.

Featuring the Nulock brush system.

The brush is simply pushed and twisted to lock, making fitting and removal a simple process.

Slide the brush / pad under the brush deck.

Fit the brush / pad onto the Nulock drive chuck, twist to lock the brush / pad in place.

Safety gloves are recommended for the changing of used brushes.

Turn on the clean water tap.

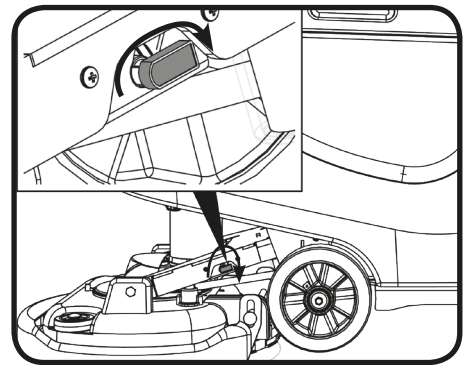
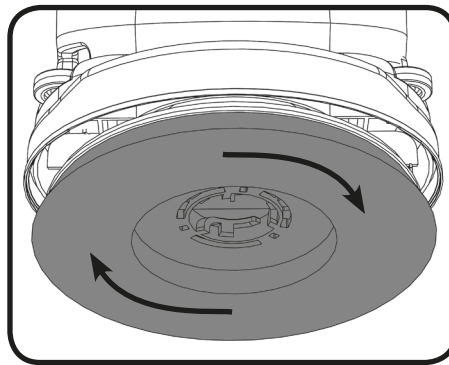
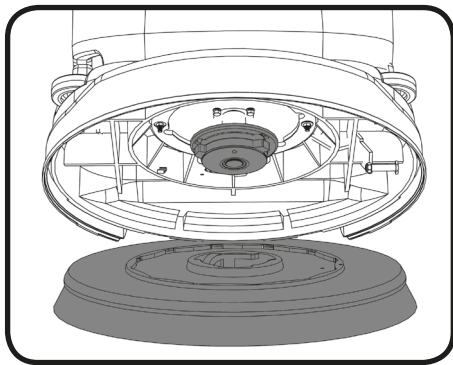

Fitting the Floor Tool

The floor tool has been designed for quick fitting, allowing easy squeegee blade replacement and a safety knock-off feature if the floor tool gets snagged, whilst in transit.

NOTE: It is easier to fit the floor tool if the weight of the machine is resting on the brush. Ensure the brush is fitted first.

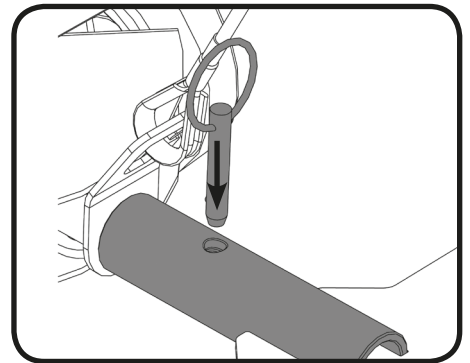
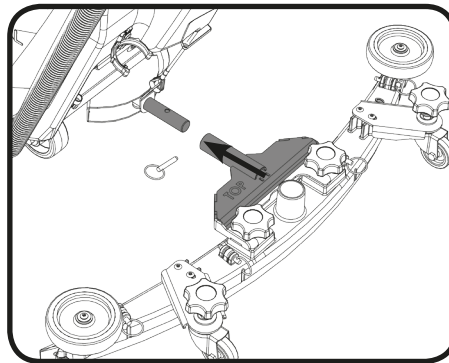
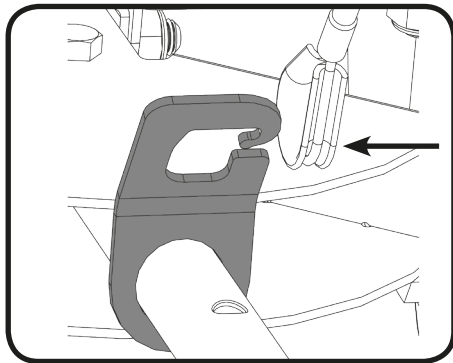

Fit the floor tool and retain using the detent pin.

Push waste collection pipe onto the floor tool; ensure a tight fit.

Raise the floor tool for transit or lower for cleaning operation using the lifting handle fitted to the back of the machine.

For fitting the floor tool blades
(See Page 12).

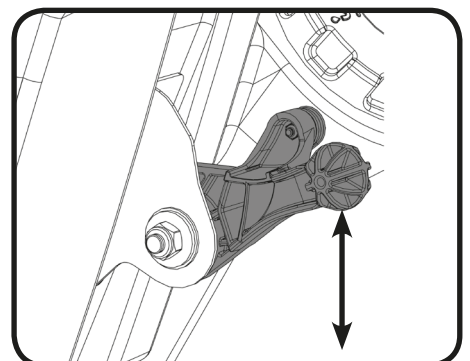
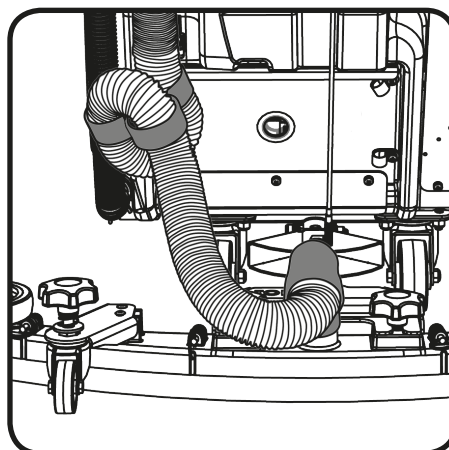

Fitting the Hose Guide

The vacuum hose has a U-bend clip which creates a U-bend in the hose preventing water spillage when the vacuum is switched off. If you need to remove the U-bend clip for any reason always ensure it is refitted correctly before you resume operation.

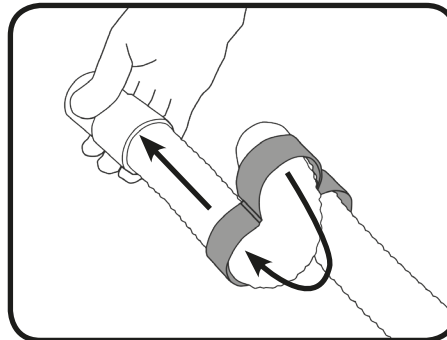
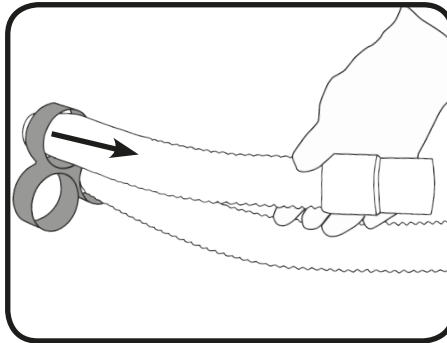
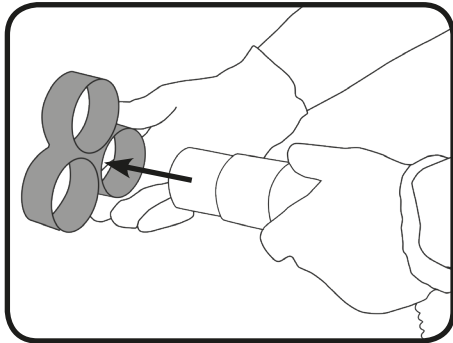

NOTE: DO NOT push the vacuum hose onto the floor tool with the floor tool in the raised position.

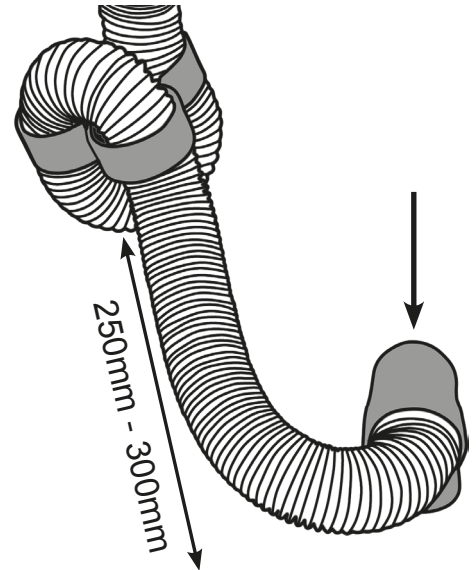

Refit vacuum hose to the Floor tool when finished.

Filling the Clean Water Tank

The TGB 6055/100 is equipped with a large capacity clean water tank allowing for large areas to be covered in a single fill.

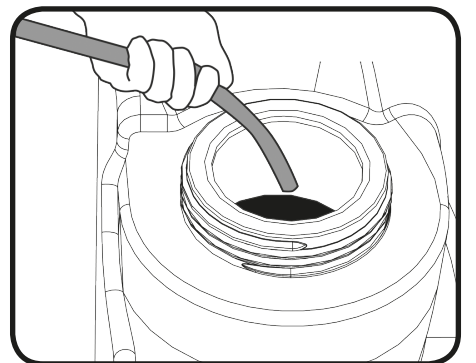
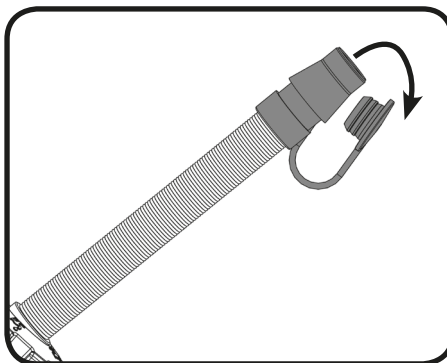
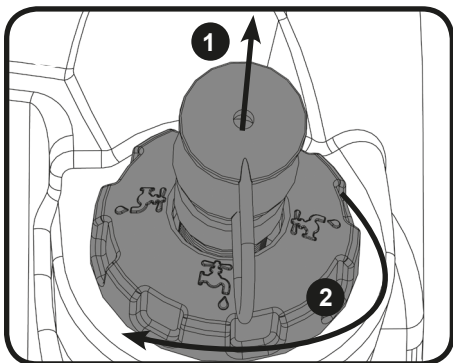

To fill the clean water tank, extend the hose located to the rear of the machine in the centre of the removable filler cap **(1)**. Pull out hose. Open the stopper and place hose under water tap, or use a hose to commence filling. The tank can also be filled by unscrewing the filler cap and using a bucket or similar container **(2)**.

NOTE: Great care must be taken to ensure that contaminants (leaves, hair, dirt, etc.) are not allowed to enter the clean water tank during the filling process. If using a bucket or similar, ensure it is always clean and free from debris.

Machine Set-up Guide

Fill Level Indicator

The water level in the clean-water tank can be measured using the scale on the left rear side of the machine. The clean water bottom tank holds 60 litres.

NOTE: always ensure that the waste water tank is empty before lifting.

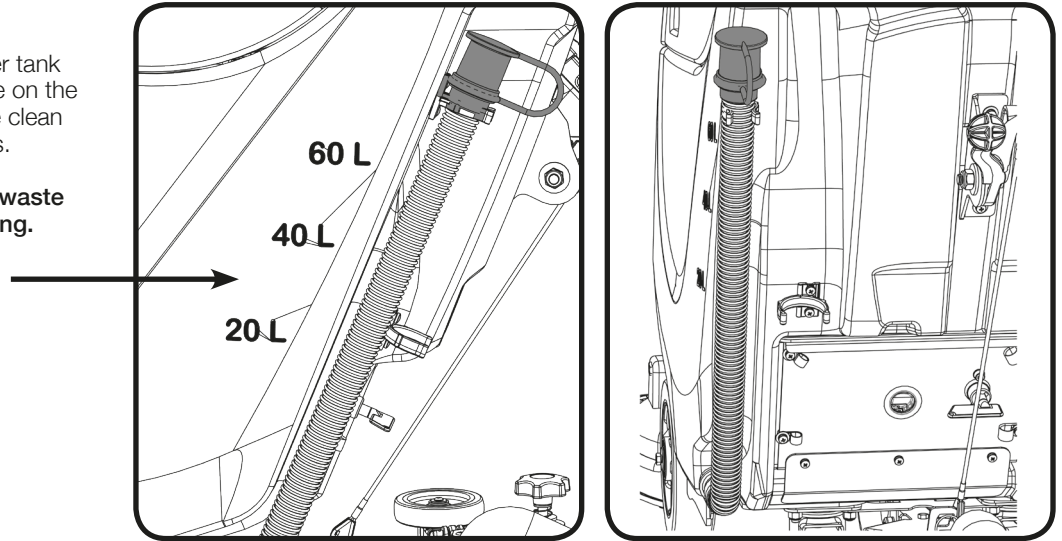

WHEN HANDLING AND MIXING CHEMICALS
Always ensure that chemical manufacturer's safety guidelines are followed.
Only use chemicals recommended for use in auto scrubber-dryers.



IMPORTANT
Do not operate machine unless the Operator Manual has been read and fully understood.



The machine is now ready to be moved to the cleaning site.

Before performing the cleaning operation, place out appropriate warning signs and sweep or dust-mop the floor.

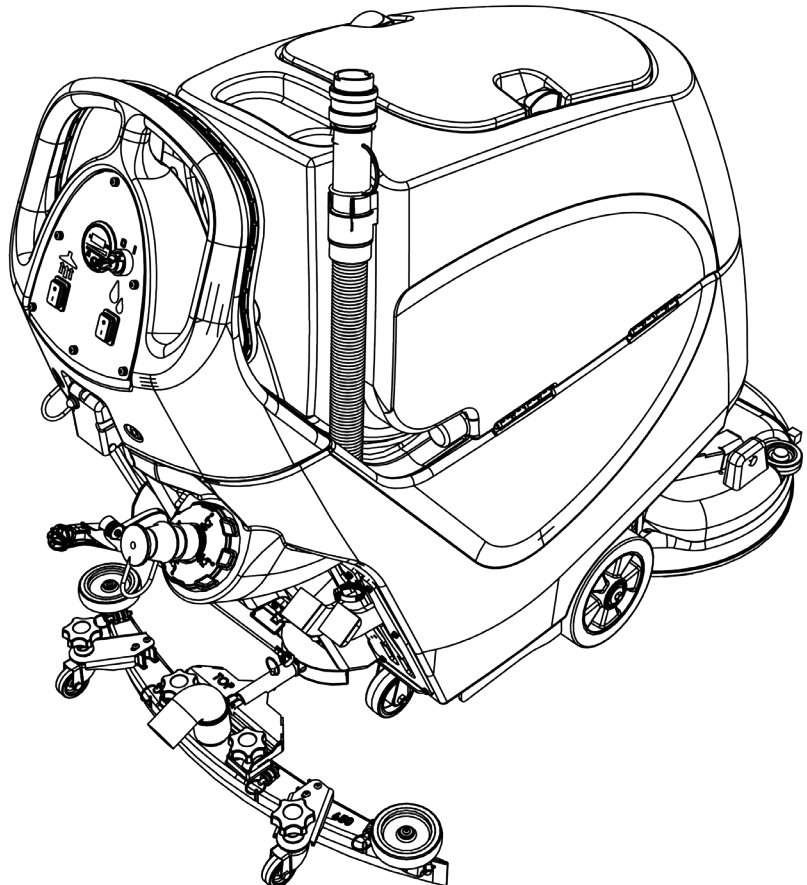
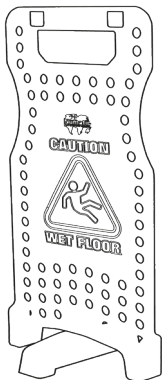

Raising/Lowering the Floor Tool

After preparing the floor (see previous section), we are now ready to set the controls to suit the cleaning conditions. Before any settings can be applied, ensure the brush deck is lowered. Move the floor tool lever to its lower position.

NOTE: Do not pull the machine backwards with the floor tool in the lowered position, this could possibly damage the blades.

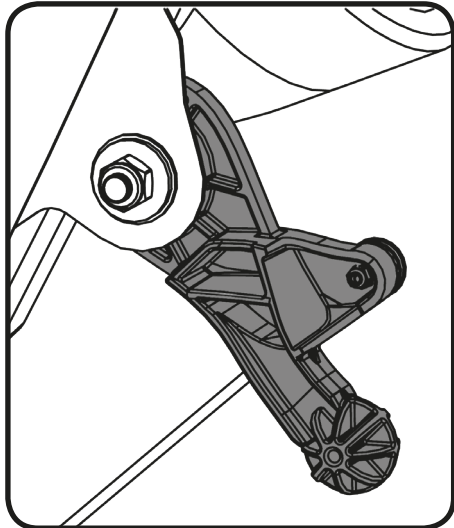
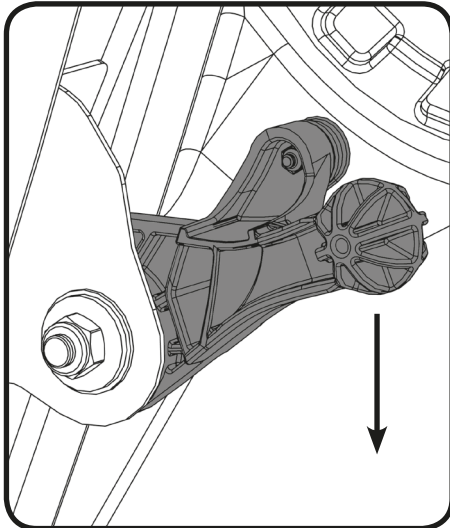
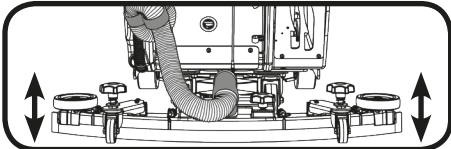

Raising/Lowering the Brush Deck

The control for lowering the brush deck can be found to the rear right of the machine. Lower the brush deck by moving the left hand release lever to the upper position.

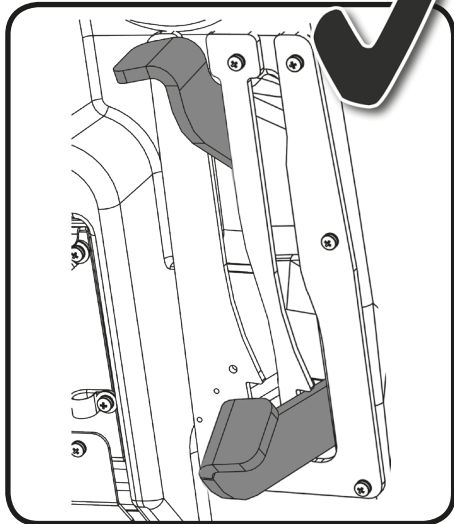
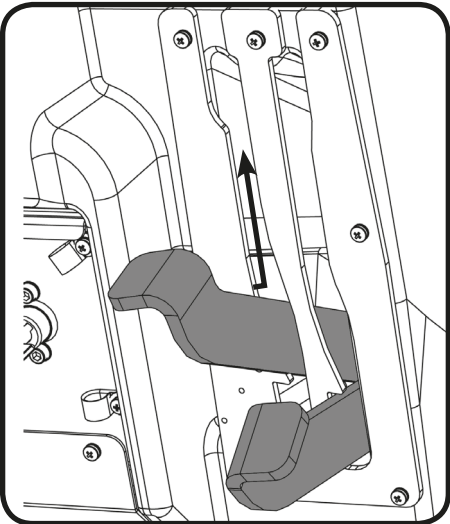
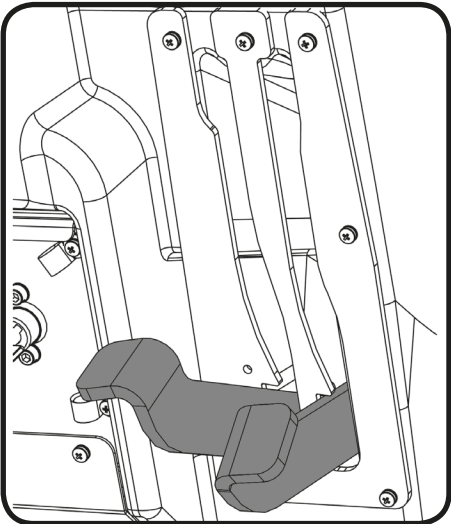
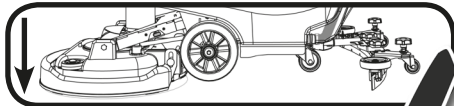

Setting the Cleaning Controls

Using the control handle with both hands, push the machine forward. The battery charge level meter will illuminate for 5 seconds. **(Fig. 1)** Switch on the Water Flow Rate **(Fig. 2)**, and vacuum pick up **(Fig. 3)**.

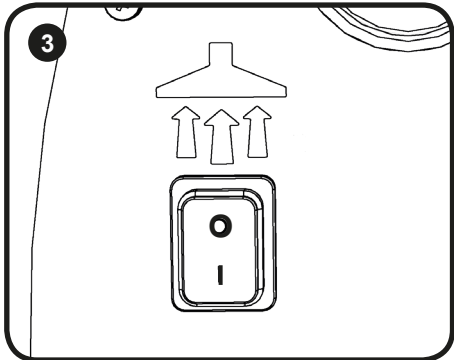
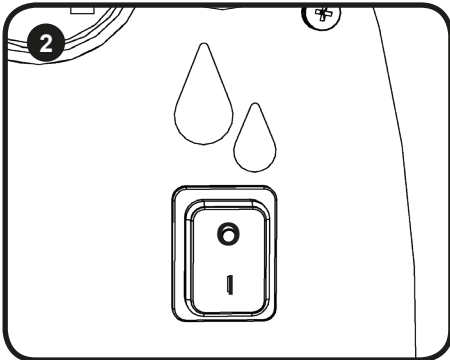
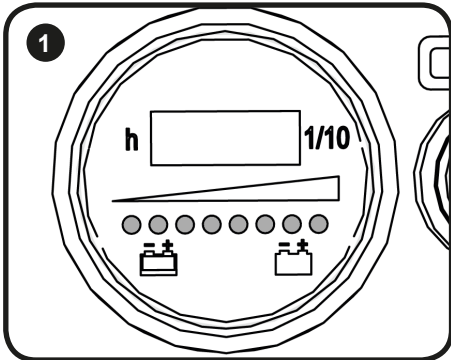

Machine Operation

Brush Pressure / Load Adjustment

The brush load lever is located to the right hand side of the machine.
This option is for hard to clean patches, adding extra pressure to the brushes.

**NOTE: It is recommended this option is NOT used all the time and is for spot cleaning only.
The run-time of the machine may decrease if the load on the brushes is increased.**

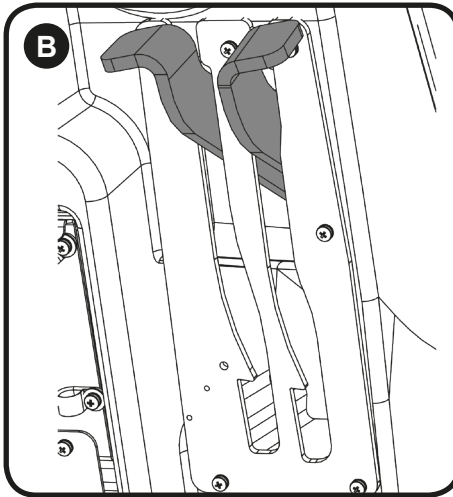
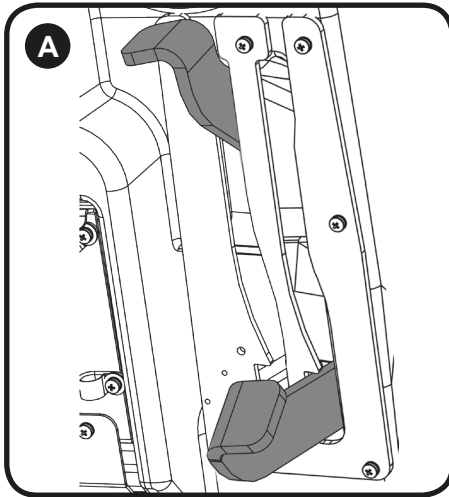

(A) Standard Duty
24 Kg Pressure

(B) Heavy Duty
32 Kg Pressure

Break-away Floor Tool

The floor tool design incorporates a break-away feature.

Allowing it to safely disengage from its mounting should it become caught on an obstruction, during forward machine movement.

To re-attach the blade to its holder. First loosen the retaining knobs on the floor tool body and slide onto the holding bracket. Tighten retaining knobs to finger tight.

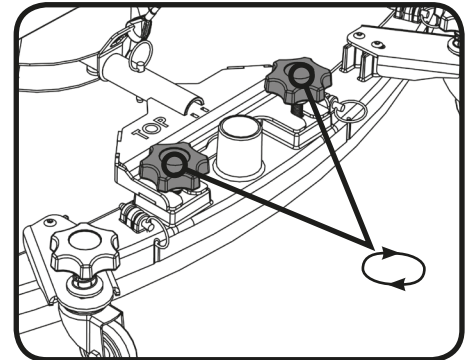
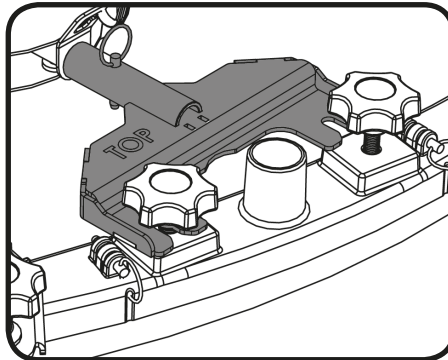

**ALWAYS ENSURE THAT THE FLOOR IS PRE-SWEPT
AND RELEVANT SAFETY SIGNS ARE DISPLAYED.**



Machine In Use

To operate, set water flow rate tap, lower brush deck, lower the floor tool, press the vacuum / water switches, pull brush On/Off trigger.

The waste water is then retrieved by the suction floor tool.
Overlap each scrubbing path by 10cm to ensure an even clean.

Do not operate the machine on inclines that exceed (2%), (9%) for Traction machines, when full.

On heavily soiled floors use a 'double scrub' technique.

First pre-scrub the floor with the floor tool in the raised position, allow the chemical time to work then scrub the area a second time with the floor tool lowered.

If streaking occurs wipe floor tool blades clean.

NOTE: Care must be taken to reduce speed when cornering or when manoeuvring around obstacles

! ALWAYS ENSURE THAT THE MACHINE IS SWITCHED OFF PRIOR TO ANY MAINTENANCE USING THE MASTER CONTROL ON/OFF KEY. REMOVE THE KEY PRIOR TO ANY MAINTENANCE OPERATION. !

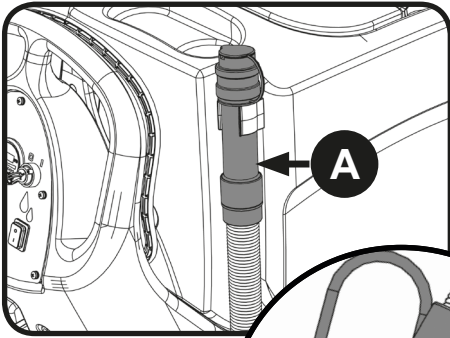

- A** After use, empty waste water tank using emptying hose and flush out with clean water.
- B** Next remove floor tool vacuum hose and flush out with clean water.
- C** Next empty clean water tank, using emptying hose and again flush out with clean water.

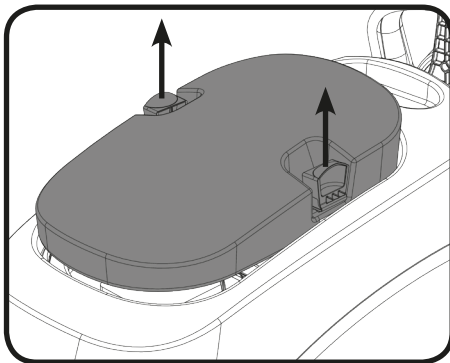
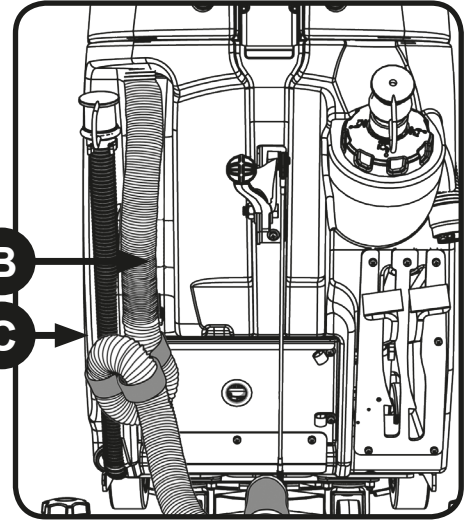
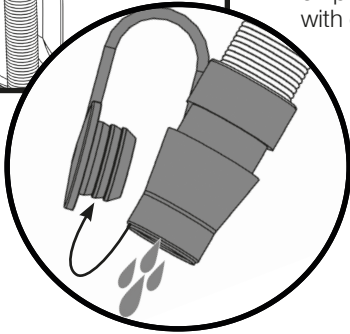

Whilst pressing in the top tank hood toggles, remove the hood. The hood also has a sealing-rubber which should be examined at every clean-down. Rinse using clean water, avoiding the vac filter.

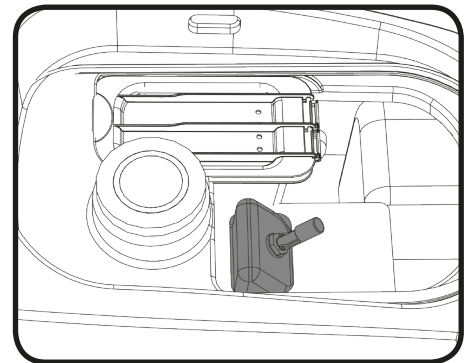

Located in your waste water (top) tank is a full tank switch, this stops your machine from working once the waste water reaches its maximum limit. Sometimes the switch gets clogged and blocked, clean to ensure correct operation. Also please ensure float pad is clean and in correct position.

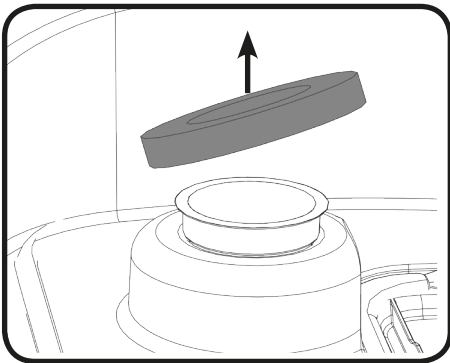

IMPORTANT
Remove vac filter and clean if required (keep dry).
Never use the machine without the recommended filter as it may cause damage to the machine.

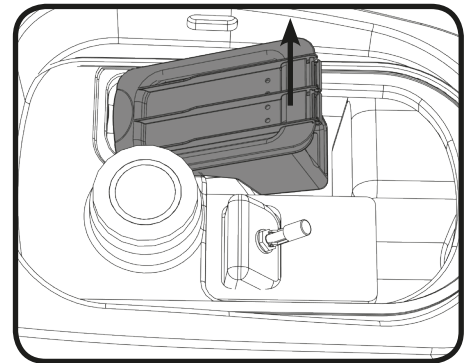

Remove debris basket filter and rinse using clean water, and refit.
IMPORTANT If the debris basket is allowed to become clogged, vacuum performance can deteriorate.

Located under the left hand side is a clean water filter, make sure the clean water tank is empty before removing this filter.
Note: To make access easier, raise the brush deck.

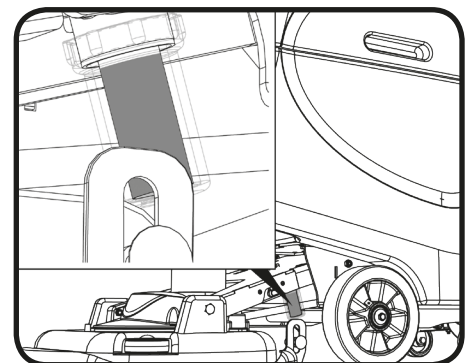

Changing the Floor Tool Blades



Always ensure that the machine is switched off prior to any maintenance.

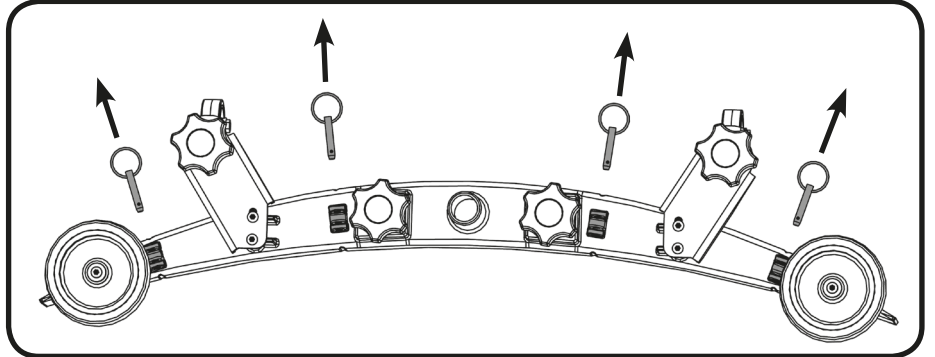
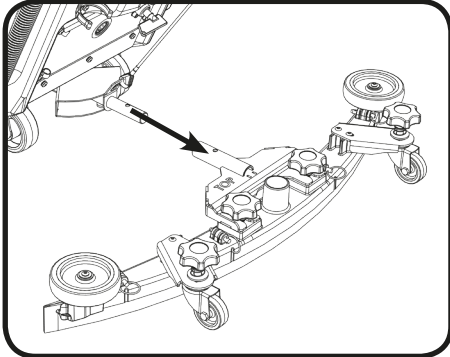

To clean the floor tool, remove securing-pin and pull-free from the holder. Rinse the floor tool assembly with clean water and refit.

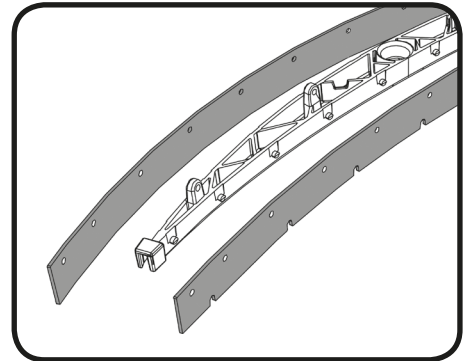
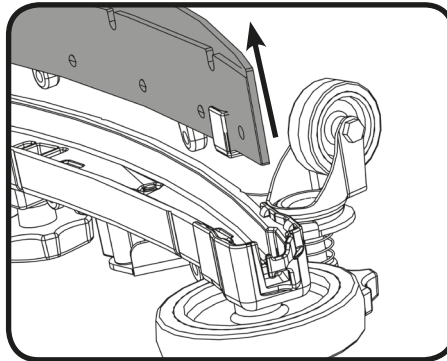
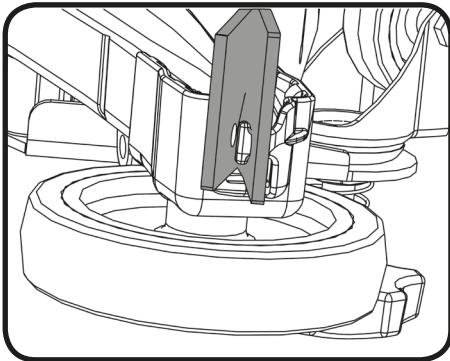

Periodically the floor tool blades should be examined and checked for wear and damage. The blade removal is easy. Simply start by removing the four retaining pins, turn the floor tool over and separate the blade carrier from the body. Peel away the blades from their locating lugs and examine or renew as required. Replacement is a reversal of the removal process.

Floor Tool Overview

1. Retaining pins x 4
2. Front blade (slotted)
3. Blade carrier
4. Rear blade
5. Floor tool main body

NOTE: The blades are designed to be reversible, thus extending their useful working life.

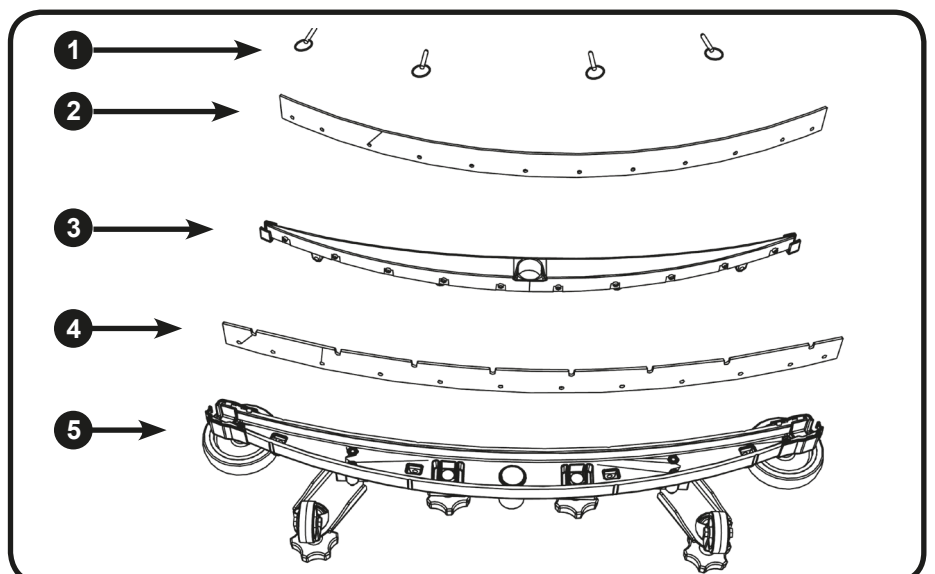



Always ensure that the machine is switched off prior to charging.



The battery meter displays the charge level of the batteries; when fully charged, all meter lights are illuminated.

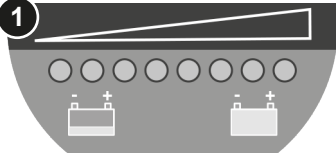

When the machine is getting close to empty the second light from the end starts to flash, the operator should then take the machine to a suitable charging point.

As the machine is used and the batteries are discharged, the meter lights will go out from right to left. If the battery-charge level is allowed to discharge to the point that only the red light remains illuminated, the operator must consider charging the machine.

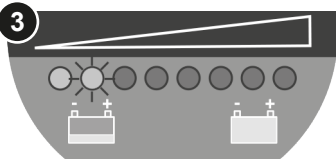
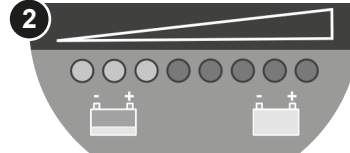

The large capacity gel batteries are sealed for life and are totally maintenance free.

The on-board charger automatically monitors the charging process and will switch off when the batteries are fully charged.

Insert the charging lead required for your country into the charging point.

The machine charging point is located to the rear of the machine under the control panel.

Connect to a suitable power supply.

Once mains power is connected the red charging indicator will illuminate.

To ensure a full charge, the machine should be left for a period of 8 hrs.

Once fully charged, disconnect the charging lead from both the power supply and the machine.

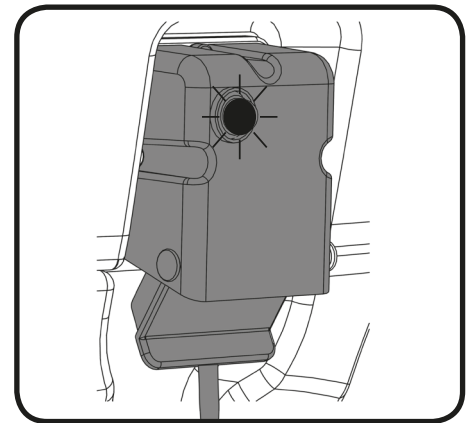
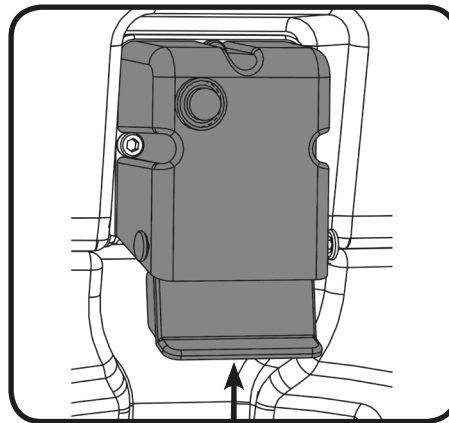
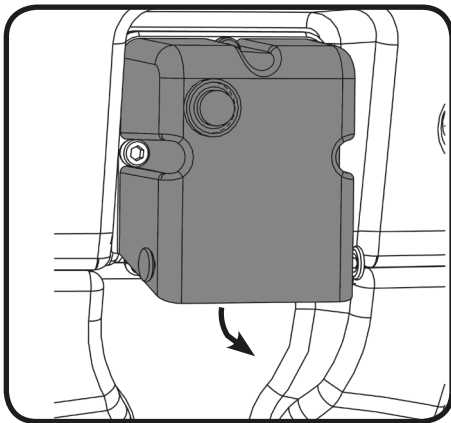

External Charging Point

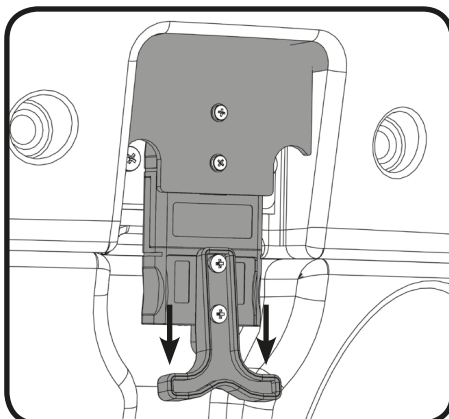

ALWAYS ENSURE THE MACHINE IS SWITCHED OFF PRIOR TO CHARGING.

Recharge batteries after each use, regardless of machine operation time.

The machine charging point is located to the rear of the machine under the control panel.

Remove Isolator Plug and connect your external charger.

Refit Isolator Plug before operating the machine.

Note: Only use the recommended charger and leads. Contact Numatic International Ltd for recommended charger and leads.

Battery Care



To ensure your machine remains at its maximum efficiency and prolong your battery life, please follow the simple steps below:



UNDER NORMAL DAILY USAGE:

Re-charge the machine FULLY after each use regardless of machine operation time. Do not leave the machine in a discharged state.

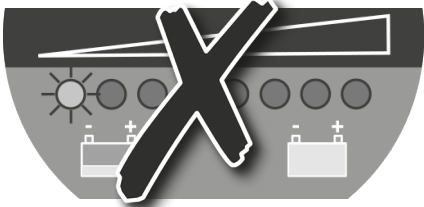

Periodically inspect the battery connections for tightness and corrosion

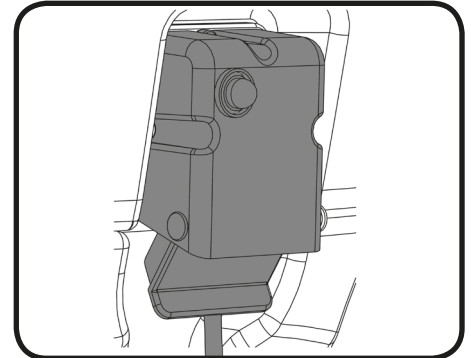

Charging Light Sequence

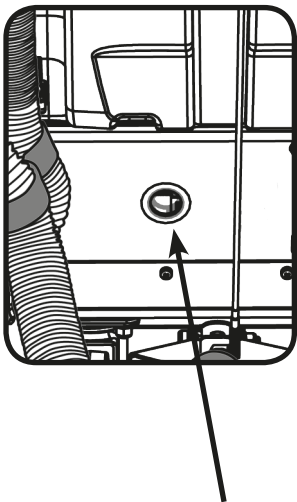

Signal (LED)	Meaning
Red LED on	First Phase (Constant current Mode)
Yellow LED on	Second Phase (Constant Voltage Mode)
Green LED on	Third Phase (Constant Voltage Mode) Charge Complete
Red LED flashing followed by Pause	Charging System Error Unsuitable battery or charging malfunction, safety timer exceeded, Internal short circuit, disconnect from power supply, switch power supply, OFF then ON, to restart the charging cycle
Yellow LED flashing	Battery not connected

Re-charge the machine fully after its last use.

Do not leave the machine in a discharged state.

Under abnormal use;

i.e. leaving the machine without charging for a period of time, we advise that you follow these steps:

If the machine will be standing unused for a period of 30 days or more, then batteries must be fully charged and battery fuses removed using the maxi fuse-puller provided, prior to this period.

Batteries should be re-charged every three months.
Charge fully the day before you start using the machine again.

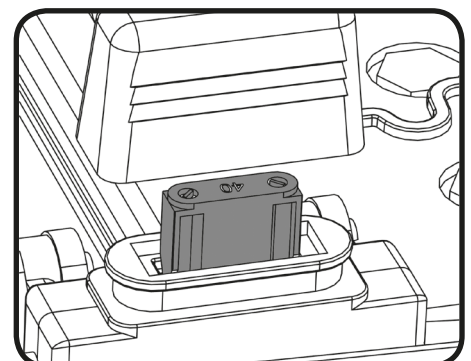

BATTERY SCRUBBER DRYER, TRACTION DRIVE

TGB 6055/100T

Control Panel Overview

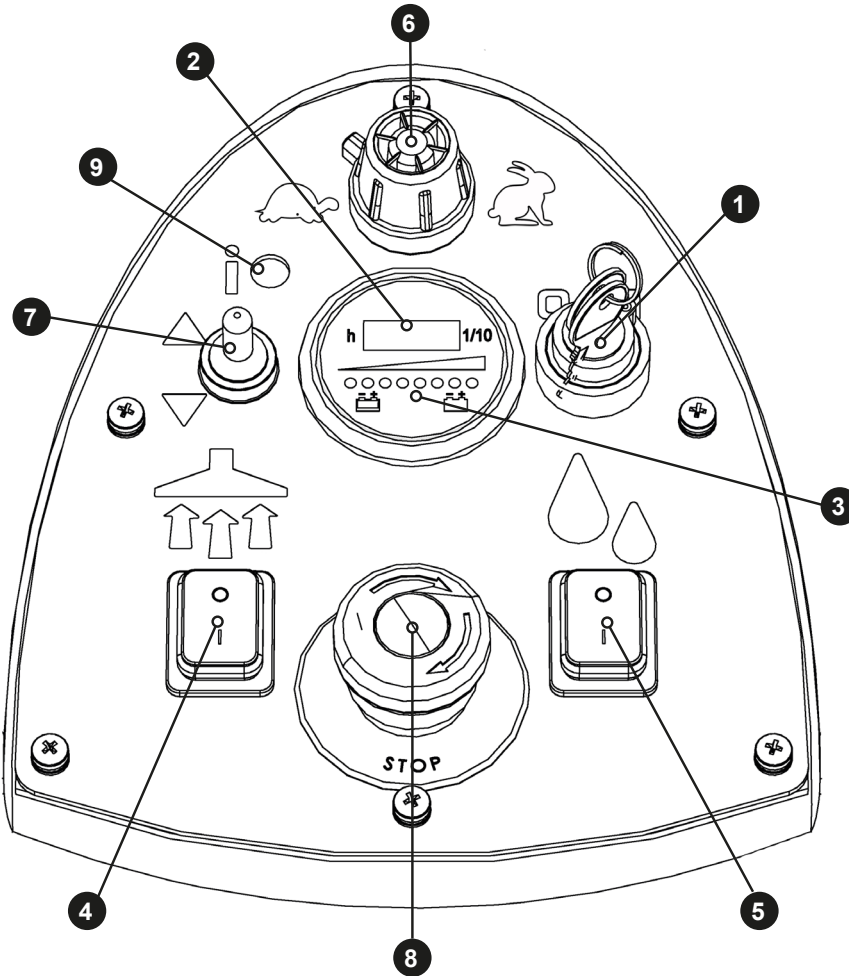

1	Key Ignition Switch
2	Hours Meter
3	Battery Charge Level Indicator
4	Vacuum Pick Up On / Off
5	Water Flow On / Off
6	Speed Control Dial
7	Forward / Backwards Control
8	Emergency Stop Button
9	Traction Status Light

In the event of a breakdown contact your Numatic dealer or the Numatic Technical help line +44 (0)1460 269268

Machine Operation.

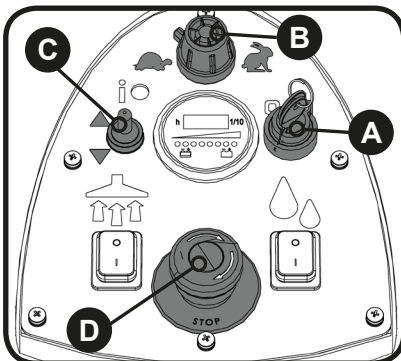

Ensure the Emergency Stop button is released (Fig.D).
 Insert the Ignition key and switch the machine on. (Fig. A)
 Ensure that the forward / reverse switch is set to forward position (Fig.C).
 Select the slow speed setting (Fig.B).

Depress control handle with both hands and slowly drive machine off of the pallet (Fig.E).
 When the machine is removed and in a safe position, turn key back to the position (0) 'OFF'

Note: During vehicular transportation ensure the product is secured to avoid unnecessary movement.

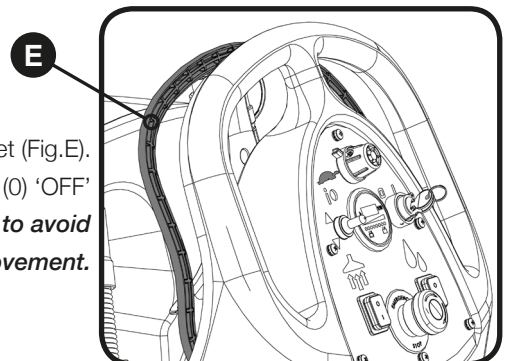

Machine Operation

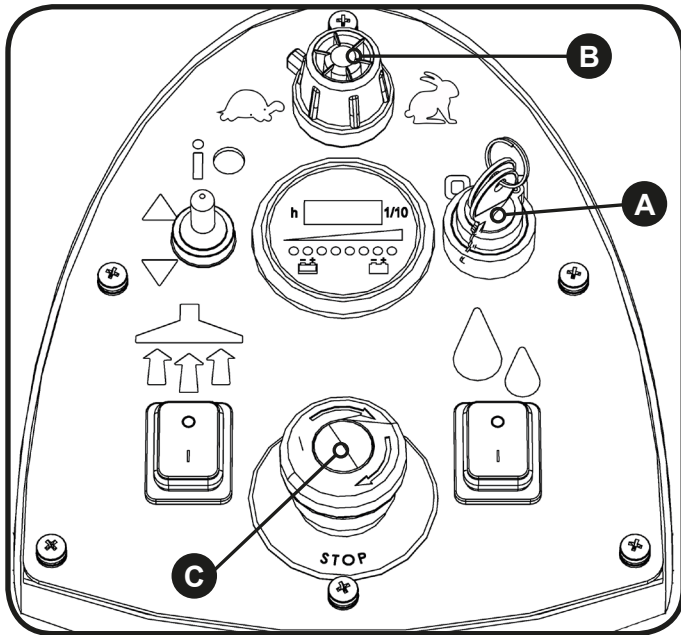

Setting the Cleaning Controls

Insert the key, turn the main control on / off key to position '1'. **(Fig.A)** The battery charge-level indicator will illuminate for 5 seconds.

Set desired traction speed as required, depending on floor type and level of soiling **(Fig.B)**.

Middle speed is the optimum cleaning speed.

The TGB 6055/100T is equipped with an electronic braking system.

Simply release the hand operated start / stop trigger and the machine will stop.

In an emergency, strike the Emergency Stop button. **(Fig.C)**. The machine will be disabled.

To reset, turn Emergency Stop button clockwise.

After re-setting the Emergency Stop button, to restart the machine, turn the main control on / off key to '0' and then position '1'.

Free Wheel Function

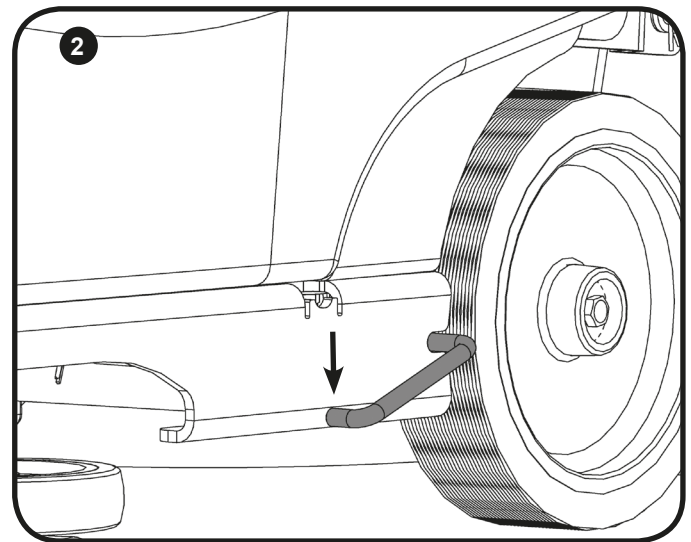
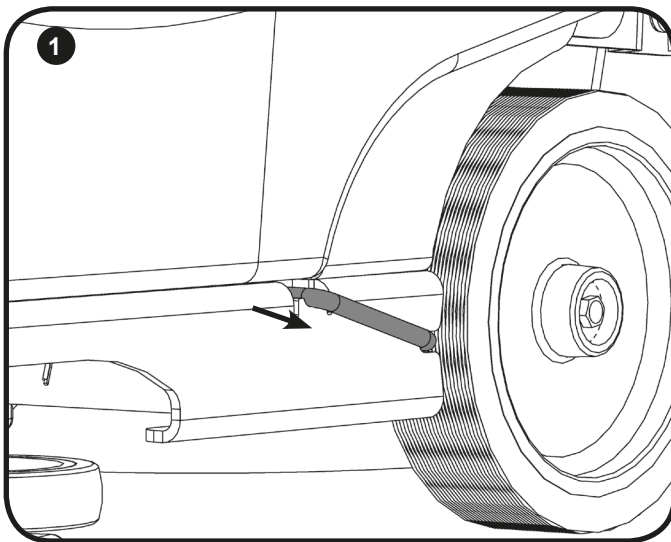

The TGB 6055/100T is equipped with a free-wheel function that will enable the operator to move the machine manually if required.

The motor brake is located on the right side of the machine near the rear wheel.

Pull the arm out **(Fig.1)**. Swing to the disengaged position **(Fig.2)**.

The motor brake will be fully disengaged. The machine will now be in full free wheel mode.



ALWAYS ENSURE THAT THE MACHINE IS ON LEVEL GROUND BEFORE DISENGAGING BRAKE ARM. NEVER DISENGAGE THE BRAKE WHEN THE MACHINE IS ON A SLOPE / GRADIENT.



Note: None of the other functions on the machine will work whilst in the free-wheel mode. Remember to re-engage the drive when you reach your final destination / before using the machine.

Specifications

Model - TGB 6055/100 & 6055/100T							
Brush Motor	Vac Motor	Brush Sizes	Pad sizes	Net Weight	Gross Weight (Full)		
300 W	400 W	550 mm	508 mm	80 Ah - 156 Kg 100 Ah - 165 Kg	80 Ah - 216 Kg 100 Ah - 225 Kg		
Protection Class	Run Time	Water Capacity	Fluid Flow	Noise	Maximum Climbing Gradient		
IPX4	2.25 hrs MAX	60 L	0 - 2 L/Min	71.4 dB(A)± 3dB(A)	Scrubbing 2 %		
Traction Drive Motor	Net Weight 6055T Model		Gross Weight (Full) 6055T Model		Maximum Climbing Gradient 6055T Model		
250W	80 Ah - 163.5 Kg, 100 Ah - 172.5 Kg		80 Ah - 223.5 Kg, 100 Ah - 232.5 Kg		Scrubbing 9 %		
Brush Speed	Scrub Pressure Standard	Scrub Pressure Heavy	Dimensions	Hand Arm Vibration	Re-charge Time	Charger	Drive Speed
100 Rpm	24 Kg	32 Kg	Width = 560 mm Length = 1425 mm Height = 1120 mm	6055-0.44 m/s ² 6055T-0.57 m/ s ²	8 hrs	10 Amp	6055T 0-4Kph

Trouble Shooting

PROBLEM	CAUSE	SOLUTION
Machine will not operate	Missing or blown fuses Low battery charge Machine is connected and charging Waste tank full switch stuck or clogged Key is off or missing handle safety fuse blown	Fit or replace fuse (page 5) Charge batteries (page 13 / 14) Take off charge (page 13) Inspect & clean switch inside tank (page 11) Insert key & turn to operating position Replace fuse (or contact service engineer)
Vacuum will not operate	Missing or blown fuse Vacuum switch not engaged Waste water tank full	Fit or replace fuse (page 5) Press switch Empty waste water tank (page 11)
Poor water pick-up	Waste water tank full Clogged / blocked vacuum hose Loose hose connections Debris basket filter clogged / blocked Separator filter clogged / blocked Poor separator seal Damaged separator seal Damaged / split vacuum hose Damaged floor tool blades Low battery charge Floor tool incorrectly adjusted	Empty waste water tank (page 11) Remove and clean (page 11) Push tight connections (page 7) Remove and clean (page 11) Remove and clean (Page 11) Clean and refit (page 11) Renew (contact service dept) Renew (contact service dept) Renew (contact service dept) Re-charge batteries (page 13 / 14) Adjust floor tool
No brush / scrub function	No brushes fitted Brush deck raised Lever not pressed Missing or blown fuses	Check and fit (page 6) Lower brush deck (page 9) Press lever Fit or replace fuse (page 5)
Little or no water flow-	Clean water tank empty Clean water tank filter blocked / clogged Water flow not on Brush deck raised Tap not opened Solenoid blocked	Fill clean water tank (page 7) Remove and clean (11) Switch on water flow (Page 9) Lower brush deck (page 9) Open tap to desired flow Clean solenoid seal
Machine just 'stops' during operating	Too much load on the brush system Brush motor fuse blown due to high load Handle safety fuse blown	Decrease the brush load to best suit the floor type (page 10). Replace fuse & reduce load (page 5) Replace fuse (or contact service engineer)

Failure to rectify the problem or in the event of a breakdown contact your Numatic dealer or Numatic Technical helpline +44 (0)1460 269268

Green Status Indicator		Fault	Possible Cause	Effect on Product	Investigate the Following	Action Required	If Fault Persists
1	Flash with pause ●	Batteries voltage low	Batteries not been charged Possible bad connection between batteries, controller, charger or fuses caused by loose connections, damaged wiring, water ingress Not accepting charge due to faulty battery / cell Charger not functioning	Operating time severely reduced or machine will not operate	Check when machine last charged Switch OFF the machine : Remove Fuses Check connections to batteries, charger and fuses for loose wires or screws	Charge batteries immediately Tighten loose connections and replace damaged components	
2	Flashes with pause ●●	Traction motor disconnected	The motor has a bad connection Motor disconnected TCO activated (Thermal Cut Out) Motor failed to open circuit	The motor will not operate	Check each battery Voltage individually to detect defect unit 10.5V min Check battery voltage and charge current ensuring charger red fault light is extinguished	Replace batteries as required Replace charger	
3	Flashes with pause ●●●	Traction motor wiring trip	The motor has a short circuit to a battery	Motor will not operate	Check all connections and leads between motor and controller	Tighten loose connections and replace damaged components	
4	Flashes with pause ●●●●	Battery Lockout	The battery charge level has fallen below the battery lockout level and the controller is inhibiting machine functions	Machine functions not working	Check battery voltage and charge current ensuring charger red fault light is extinguished Check each battery voltage individually to detect defect unit 10.5V min	Charge batteries immediately	
6	Flashes with pause ●●●●●●	Charger connected	The controller is being inhibited from driving, this may be because the battery charger is connected	Machine functions not working	Remove charger to operate machine		
7	Flashes with pause ●●●●●●●	Machine inhibited	E-Stop pressed	Machine functionality inhibited	Check E-Stop	Release E-Stop and cycle key switch	
8	Flashes with pause ●●●●●●●●	Controller trip	A controller trip is indicated	Machine functions not working	Check all connections and leads	Tighten loose connections and replace damaged components	
9	Flashes with pause ●●●●●●●●●	Brake deactivated or failed	Poor brake connections Brake failure or deactivation	Traction drive disabled	Check brake wiring and brake lever	Replace brake or wiring as necessary. Reactivate brake by engaging brake lever	
10	Flashes with pause ●●●●●●●●●●	High battery voltage	Poor connections between battery controller and traction motor	Machine functions not working	Check each battery Voltage individually to ensure voltage < 14 volts Check connections on controller batteries and traction motor		
					Check combined battery pack voltage is < 28 volts		Contact Service Agent

About the Machine

Rating Label	
1	Company Name & Address
2	Machine Description
3	Voltage Frequency
4	Power rating
5	WEEE Logo
6	Ingress Protection Rating
7	Max Gradient
8	CE Mark
9	Weight (ready to use)
10	Machine yr/wk Serial number
11	Machine Description
12	Noise Rating
13	Hand Arm Vibration

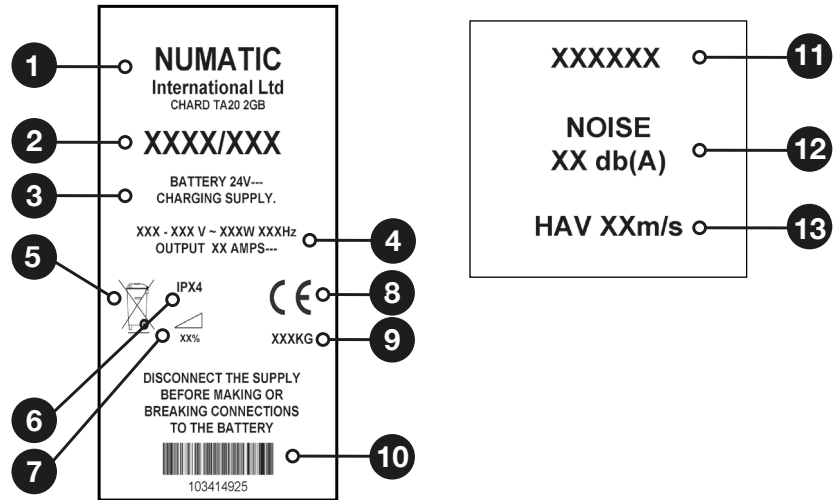

WEEE (Waste, Electrical and Electronic Equipment)

Scrubber dryer Accessories and packaging should be sorted for environmentally-friendly recycling. Only for EU countries.

Do not dispose of scrubber-dryer into household waste.

According to the European Directive 2012/19/EU on waste electrical electronic equipment and its incorporation into national law.

Scrubber-dryers that are no longer suitable for use must be separated, collected and sent for recovery in an environmentally-friendly manner.

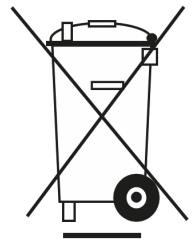

PPE (Personal protective equipment) that may be required for certain operations.

Ear Protection	Safety Footwear	Head Protection	Safety Gloves	
Dust / Allergens Protection	Eye Protection	Protective Clothing	Hi-Vis Jacket	Caution Wet Floor Sign

NOTE: A risk assessment should be conducted to determine which PPE should be worn.

Safety Critical Component:

Charging Leads: H05VV-F x 1.0 mm² x 3 Core

Battery Charger: 220V / 240V (50-60Hz)

DC Output: 24VDC, 10A

Ref page 19 for component part numbers

**In the event of a breakdown contact
your Numatic dealer or the
Numatic Technical
help line +44 (0)1460 269268**



**ORIGINAL INSTRUCTIONS
READ MANUAL BEFORE USE**

Information for Scrubber Dryer

COMPONENT	INTERVAL	INSPECT FOR
Mains Lead	DAILY	Scuffing, cracks, splits, conductors showing
Brushes	DAILY	Bristle damage, wear, drive collar wear
Squeegee Blade	BEFORE EACH USE	Wear, cracks, splits
Filters	BEFORE EACH USE	Clogging and debris retention
Tanks	AFTER EACH USE	Rinse dirty water tank after use



WARNING

As with all electrical equipment care and attention must be exercised at all times during its use, in addition to ensuring that routine and preventative maintenance is carried out periodically in order to ensure its safe operation.

Failure to carry out maintenance as necessary, including the replacement of parts to the correct standard could render this equipment unsafe and the manufacturer can accept no responsibility or liability in this respect. When ordering spare parts always quote the Model Number / Serial Number specified on the Rating Plate. Warning do not use on slopes exceeding 2%.

This appliance is not intended for use by persons (including children) with reduced physical, sensory or mental capabilities, or lack of experience and knowledge, unless they have been given supervision or instruction concerning use of the appliance by a person responsible for their safety. Children should be supervised to ensure that they do not play with the appliance. When detergents or other liquids are used, read the manufacturer's instructions.

Only use brushes provided with the appliance or those specified in the instruction manual. The use of other brushes may impair safety. A full range of brushes and accessories are available for this product. Only use brushes or pads which are suitable for the correct operation of the machine for the specific task being performed.

It is essential that this equipment is correctly assembled and operated in accordance with current safety regulations. When using the equipment always ensure that all necessary precautions are taken to guarantee the safety of the operator and any other persons who may be affected. Wear nonslip footwear when scrubbing. Use a respiratory mask in dusty environments. The machine, while charging, must be positioned so that the mains plug is easily accessible. When cleaning, servicing or maintaining the machine, replacing parts or converting to another function the power source shall be switched off. Mains operated machines shall be disconnected by removing the power plug, and battery operated machines shall be disconnected by removing the fuse.

In order to prevent unauthorised use of the machine the power key must be removed after use. Machines left unattended shall be secured against unintentional movement. When detergents or other liquids are used, read the manufacturer's instructions.

Operators shall be adequately instructed as to the correct use of the machine.

If this product does not have a factory installed Numatic battery charger, then it is the responsibility of the owner and user of the product to ensure that the charging system and battery combination are compatible, fit for purpose and safe to use.



CAUTION

This machine is not suitable for picking-up hazardous dust. Do not use on surfaces having a gradient exceeding that marked on the appliance. This machine shall be stored indoors only. This machine is for indoor use only. Read the instruction manual before using the appliance. This product meets the requirements of IEC 60335-2-72

NOTES: This machine is also suitable for commercial use, for example in hotels, schools, hospitals, factories, shops and offices for other than normal housekeeping purposes.



DO

- Ensure only competent persons unpack/assemble the machine.
- Keep your machine clean.
- Keep your brushes in good condition.
- Replace any worn or damaged parts immediately.
- Regularly examine the power cord for damage, such as cracking or ageing. If damage is found, replace the cord before further use.
- Only replace the power cord with the correct Numatic approved replacement parts.
- Ensure that the work area is clear of obstructions and / or people.
- Ensure that the working area is well illuminated.
- Pre-sweep the area to be cleaned.



DON'T

- Use steam cleaners or pressure washers to clean the machine or use in the rain.
- Attempt machine maintenance or cleaning unless the power plug has been removed from the supply outlet.
- Allow any inexperienced repairs. Call the experts.
- Strain cable or try to unplug by pulling on cable.
- Leave the brush pad on the machine when not in use.
- Allow the machine to be used by inexperienced or unauthorised operators or without appropriate training.
- Use the machine without the solution tanks properly positioned on the machine, as shown in the instructions.
- Expect the machine to provide trouble-free, reliable operation unless maintained correctly.
- Run the machine over power cable during operation.
- Lift or pull the machine by any of the operating triggers, use the main handle.
- Remove the handle from the machine except for service and repair.



**ORIGINAL INSTRUCTIONS
READ MANUAL BEFORE USE**

Information for Scrubber Dryer

Precautions when working with batteries

1. Always wear protective clothing e.g. face visor, gloves and overalls when working with batteries.
2. Whenever possible always use a properly designated and well-ventilated area for charging.
Do not smoke or bring naked flames into the charging area.
3. Remove any metallic items from hands, wrists and neck i.e. rings, chains etc. before working on a battery.
4. Never rest tools or metallic objects on top of the battery.
5. When charging is complete disconnect from the mains supply.
6. The batteries must be removed from the machine before it is scrapped.
7. The machine must be disconnected from the supply when removing the battery.
8. To remove the batteries:- Disconnect machine from the mains supply (if charging) and ensure batteries are switched off with circuit disconnect switch (see page 19). Disconnect hoses from separator and tanks.
Remove separator and tanks. Unscrew battery strap fixings and remove.
Undo battery terminals and remove. Remove batteries.
9. The batteries are to be disposed of safely, as according to local government guidelines.
10. Only use genuine Numatic replacement batteries.
11. Do not allow the batteries to become fully discharged; it may not be possible to re-charge them.
Batteries should not be discharged below 9.5 volts with 10 amps flowing.
12. Do not allow one battery to be discharged separately to the other.
13. Do not mix batteries from different machines.
14. The batteries fitted to this product are Valve Regulated Lead Acid (VRLA) gel electrolyte type.
The fitting of any other type of battery may cause a safety hazard.
15. Disconnect the fuse between the batteries before cleaning or maintenance.

Battery Care

1. Battery Storage:

- a. Batteries must be stored in a dry, level and clean location not exceeding a temperature range of 5°C to 25°C.
- b. Batteries must be fully charged after 6 months when on-the-shelf and as a minimum every 3 months thereafter or if the battery voltage reduces to 12.6V.
- c. Batteries must be put into use within 12 months of the date of manufacture, failure to do so will lead to reduced capacity in the field.
(battery date code) - silver label on the battery - (e.g. 1649) = Year - 2016 / Week - 49.
- d. If a battery reaches 10.5V, irreversible damage has occurred. Under this condition, a battery should not enter into service and should be disposed of according to local authority guidelines.

2. During Use:

- a. Batteries must be recharged after every use regardless of machine run time
- b. If the machine is to be left dormant for any length of time complete the following:
 - i. Fully charge the batteries and remove the battery fuses
 - ii. Every 3 months insert the fuses and recharge
 - iii. Do not leave batteries dormant for more than 6 months

3. Warranty:

- a. Batteries are warranted for 600 cycles (2 Years) providing all battery care rules are followed
- b. To claim warranty the following details must be supplied
 - i. Serial number of the machine
 - ii. Battery date code (Show picture of battery date code)
 - iii. Date purchased
 - iv. Proof of Purchase
 - v. Maintenance history and charging regime

Daily

**Keep the machine clean.
Ensure brushes/ pads/ squeegee/ filters are in good condition.
Check for any worn or damaged parts and replace immediately.
Drain and rinse dirty water tank after every use.
Store machine with brush deck secured in tilted position.**

Weekly – as daily and –

**Check brush or pad and skirt and rinse.
Check floor tool blades for wear and wipe clean.
Clean separator assembly including filter and check condition of seal.
Flush out system with clean water and clean filters.
Do not steam clean or pressure wash.**

Batteries

**Always re-charge the batteries after use.
Charge for a minimum of 4 hours after the green light has come on, this will prolong battery life.**

**TwinTec
Maintenance**

Battery Model	Battery Weight	Battery Dimensions
MK Battery	31.8 Kg	327.5mm x 169mm x 218mm

Spare Parts

BRUSHES		HOSES	
606028	550 mm Polyscrub Brush	903325	Hose Closure (Bottom Tank)
606550	550 mm Nyloscrub Brush	903341	Hose Closure (Filling Hose)
606551	550 mm Long Life Brush	901548	Top Tank Hose (Adjustable Flow)
900526	500 mm NuLoc2 Drive Board	GENERAL PARTS	
Part No.	SQUEEGEE	206953	Detent Pin
903281	Squeegee Knob	204120	Drive Wheel
215006	Squeegee Castor Wheel	204116	Rear Castor
606319	Squeegee Castor Assembly Set	220386	Charging Lead V17 - UK
900518	Squeegee 650 Blade Set	221107	50 Amp Maxi Fuse (Traction Machine)
904691	Complete 650 Squeegee Assembly	221047	40 Amp Maxi Fuse (Battery Machine)
900519	Squeegee 750 Blade Set	221091	20 Amp Maxi Fuse (Vac Motor)
904699	Complete 750 Squeegee Assembly	230104	30 Amp Maxi Fuse (Brush Motor)
Part No.	FILTERS	903066	2.5 Amp Fuse (Safety Fuse)
208888	Clean Water Filter	903323	Anti-Static Strap
903283	Filter Basket	204115	Drive wheel (Traction)
903285	Filter Basket Lid		
237688	Foam Filter Body		
208947	Foam Filter		
208950	Float Pad		

Schematic Diagram

TGB 6055/100

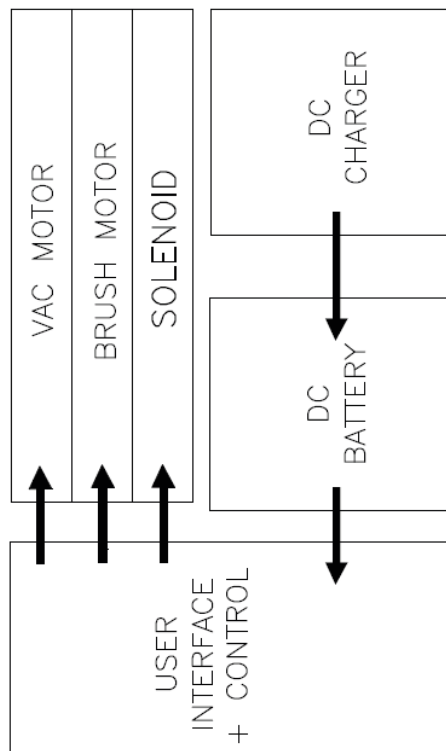

TGB 6055/100T

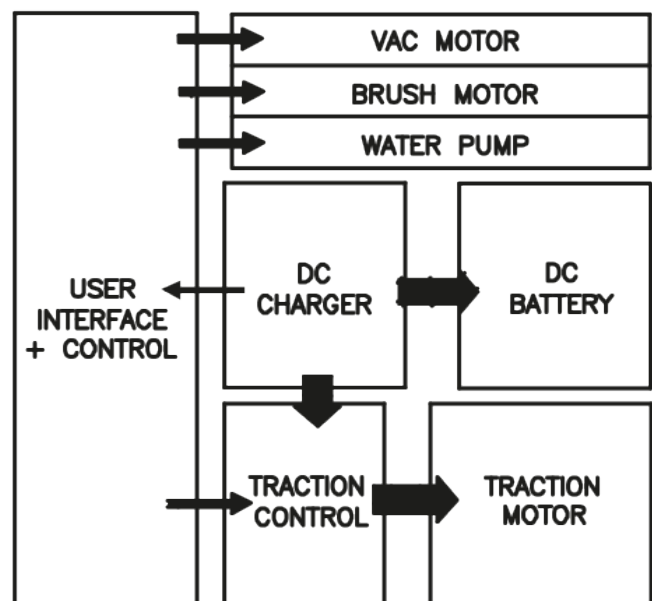

Battery Wiring Diagram

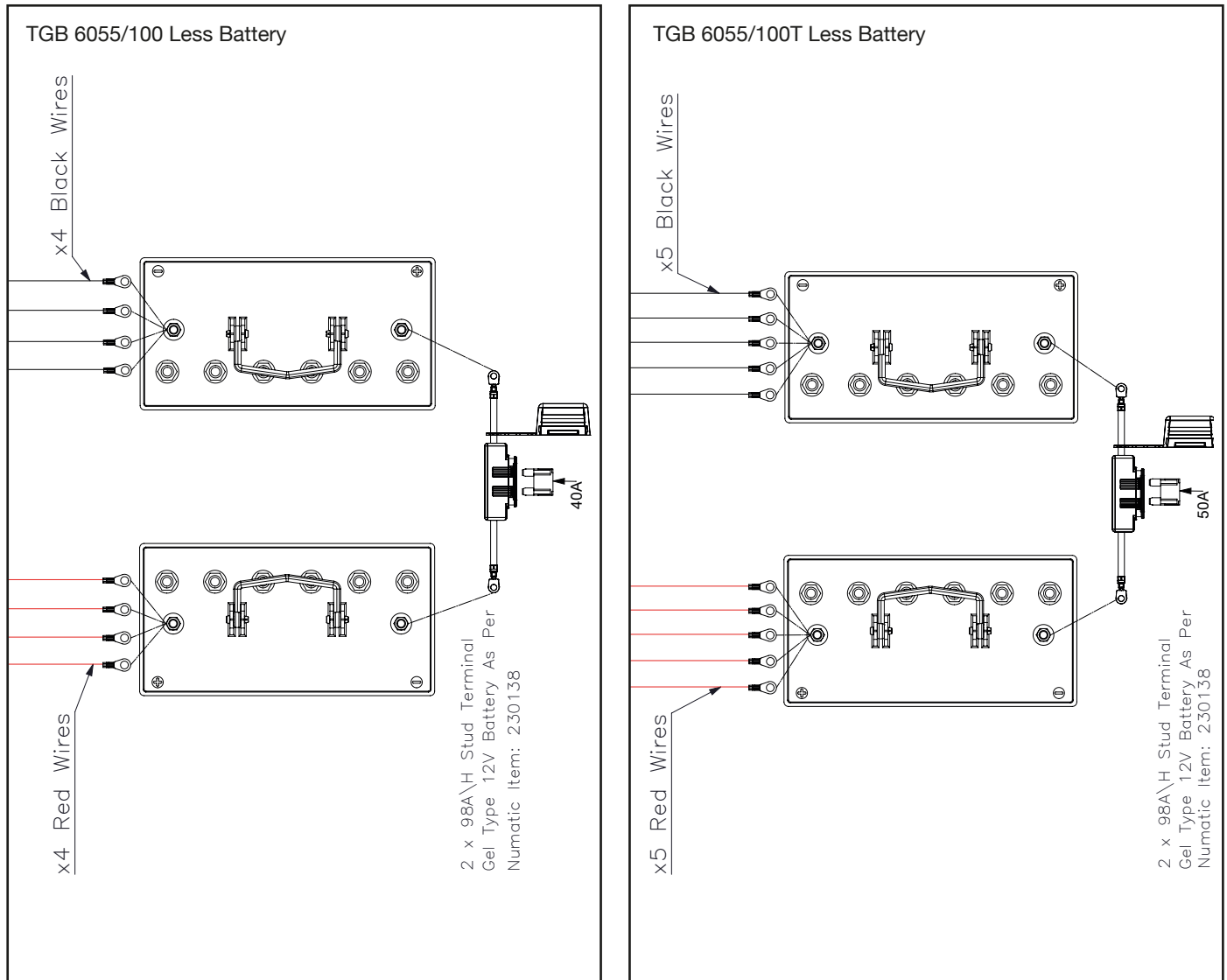

For optimum performance Numatic International Ltd recomed the use of the following batteries in the Twintec machines.

<i>Machine</i>	<i>Numatic Recommended Battery</i>	<i>Numatic Number</i>
TGB 6055 Less Battery	MK Battery - 98A/h Stud Terminal Gel Type - Suppliers Ref: E31SLD G ST	205112
TGB 6055T Less Battery	MK Battery - 98A/h Stud Terminal Gel Type - Suppliers Ref: E31SLD G ST	205112

<i>Make</i>	<i>Voltage</i>	<i>Capacity</i>	<i>Weight</i>	<i>Size</i>
MK Battery	12 V	97.6 A/h	31.8 Kg	329mm x 171mm x 237mm

EU Declaration of Conformity



EU DECLARATION OF CONFORMITY

We hereby declare under our sole responsibility that the following equipment fulfils all the relevant provisions of the following EU Directives

Machinery Directive 2006/42/EC
EMC Directive 2014/30/EU
RoHS Directive 2011/65/EU

Machine Description: Scrubber Dryer
Machine Type: TTB, ETB, TGB, HGB Series.

Relevant standards upon which conformity is declared include:

EN 60335-1: 2012 + A11:2014
EN 60335-2-72: 2012
EN 55014-1: 2006 + A1:2009 + A2:2011
EN 55014-2: 1997 +A1:2001 + A2:2008
EN 61000-3-2: 2014
EN 61000-3-3: 2013
EN 62233: 2008

A technical construction file for this equipment is retained at the manufacturer's address under the authorisation of the following signatory:

Name: Allyn Boyes Position: Development Manager

Signed

Date

9/2/17



Numatic International Ltd
Chard Somerset
TA20 2GB
www.numatic.co.uk

GB

Numatic International Warranty

Numatic International Limited warrant to the original purchaser that its products are free of defects in both material or workmanship for the period shown below:-

Homecare and Cleancare Vacuum cleaners.....	2 Years
Rotary Floor Machines.....	2 Years
Twintec Auto Scrubber Dryer.....	1 Year
Vario Ride-On Scrubber Dryer.....	1 Year / 1500 hours
Mopping, Compacts, Combi and Servocare Products.....	1 Year
Individual Accessories and Spare Parts.....	6 Months

Note: This warranty expressly excludes consumable parts such as carbon brushes, floor brushes, mops, batteries etc, that are considered replaceable from time to time during the normal working life of the machine.

- A. The warranty period commences from the date the goods are purchased.
- B. All warranty claims must be processed through the Dealer from whom the equipment was purchased. The Dealer will co-operate with the purchaser throughout the warranty claims procedure and will arrange any necessary repairs using genuine Numatic parts.
- C. If the original Dealer is no longer able to fulfil his obligations please contact Numatic International Limited with full details of the claim and proof of purchase so that this may be processed without delay.
- D. Any warranty claim can only relate to the specific part that is proven to be at fault and for which a replacement will be supplied but cannot be extended to constitute a claim against the complete machine.
- E. Numatic International will supply the Dealer with any warranty parts required, subject to the claim being validated, after return of the faulty items in accordance with Numatic International Limited's General Conditions of Sale.
- F. Claims will not be accepted if they are the result of fair wear and tear, misuse or abuse of any kind.
- G. No replacement will be given unless the appropriate evidence of the validity of the claim has been provided to the satisfaction of Numatic International Limited.
- H. Numatic International Limited reserve the right to charge for any unnecessary work carried out as a result of an invalid claim.
- I. No variation to this warranty may be made or implied by any member of Numatic International Limited or its Dealers unless such variation is in writing and authorised by the Company

Numatic International Limited. Chard, Somerset, TA20 2GB
Telephone: 01460 68600 Fax: 01460 68458
 © Numatic International Limited

**This Machine Has Been Packed
With The Following**

- | | |
|---------------|--------------------------|
| Brush / Pad | <input type="checkbox"/> |
| Floor Tool | <input type="checkbox"/> |
| NuTab | <input type="checkbox"/> |
| Charging Lead | <input type="checkbox"/> |
| Fuse Pack | <input type="checkbox"/> |

Signed

Distributed by:



Numatic International Limited.
Chard, Somerset TA20 2GB ENGLAND
Tel.: 01460 68600 www.numatic.co.uk



Numatic International GmbH. Fränkische Straße 15–19
D-30455 Hannover, DEUTSCHLAND
Tel.: 05 11 98 42 16 0 www.numatic.de

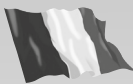

Numatic International SAS. 13 / 17 rue du Valengelier
77500 CHELLES, FRANCE
Tel: 01 64 72 61 61 www.numatic.fr



BeNeLux Distribution, Numatic International BV
Postbus 101, 2400 AC Alphen aan den Rijn, NEDERLAND
Tel: 0172 467 999 www.numatic.nl

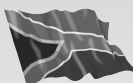

Numatic International (Pty.) Ltd.
16th & Pharmaceutical Roads, Midrand, Gauteng, SOUTH AFRICA 1685
Tel: 0861 686 284 www.numatic.co.za



Numatic International Schweiz AG.
Sihlbruggstrasse 142, 6340 Baar. SCHWEIZ
Tel: 0041 (0) 41 76 80 76 - 0 www.numatic.ch

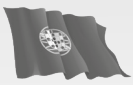

Numatic International ULDA. Centro de Negócios da Maia,
Rua Albino José Domingues, 581, 4470 – 034 Maia PORTUGAL
Tel: +351 220 047 700 www.numatic.pt

This Product has been comprehensively inspected and checked during every stage of its manufacture, including an in-depth electrical safety and functionality test.

Specification subject to change without prior notice
www.numatic.co.uk © Numatic International Limited

903816 08/18 (A08)